



E6 S Elliptical

Owner's Manual

**E6 S
Elliptical**

**Display Type:
8 inch Touch Screen**





SUPPLEMENT DESCRIPTIONS OF E6 S

Specifications





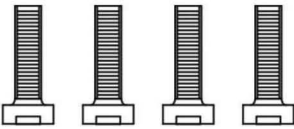
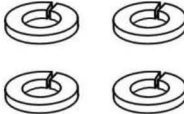
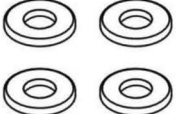
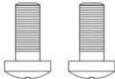

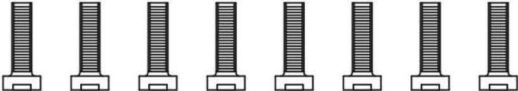
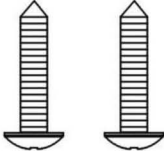
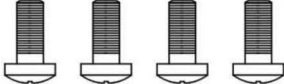
Electrical Specifications	
Power Requirement	100-240V±10 50/60Hz
Display Type	8 inch touch screen with 1 LED

Hardware kit & Tools

Please verify the hardware kit list as shown below.

STEP 1	M8x20mm Screws (4 PCS)  (for handle bar set)	M8 S Washer (4 PCS)  (for handle bar set)	M8 Washer (4 PCS)  (for handle bar set)
	M4x10mm (2 PCS)  (for console frame cover)	M4x12mm (2 PCS)  (for console frame cover)	
STEP 4	M4x12mm Screws (8 PCS)  (for left / right cover)		M3x30mm Screws (2 PCS)  (for left / right cover)
	M5 x 12mm Screws (4 PCS)  (for console set)		

Please verify the tools list as shown below.

Allen Wrench (3mm) 	Allen Wrench (4mm) 	Allen Wrench (5mm) 	Allen Wrench (6mm) 
Silicone Oil 	Power Cord 	Owner's Manual 	

SUPPLEMENT DESCRIPTIONS OF E6 S (CONTINUED)

F833714-000-00 EP-6000C1 10802

Power Cord Connection and Powering On

Connect the power cord to the **outlet #1** which is located at the front bottom side of the equipment.

Power the equipment on by plugging it into an appropriate wall outlet, then turn on the **power switch #2**.

When the power is turned on, display will light for a short time.

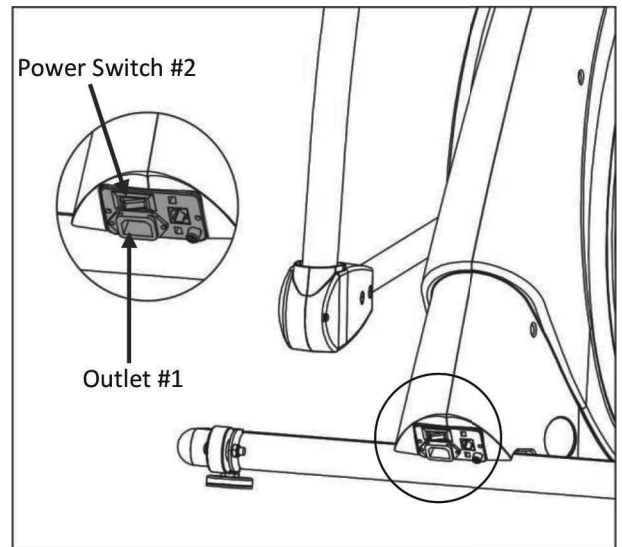

Assembly

Step 5: Assembly console with handle bar post.

WARNING: Ensure that the console wires do not become pinched or crushed as you lower the console mast to the main frame. Pinched or crushed console wires will result in shorting conditions and machine damage.

1) Unscrew the **(4) Pre-Locked Screws** on the back of Console Set.

2) Connect the **Connectors (#1, #2, #3, #4, #5)** from the **Console Mast** to the corresponding connectors located in the **Console Set**. (Fig 5.1-1)

***Connectors #1:** Grounding wire.

***Connectors #2 & #3:** Network wire and power wire.

***Connectors #4 & #5:** Heart Rate wires.

3) Tighten **(4) Pre-Locked Screws** to fix the **Console Set** on the **Console Mast**. (Fig 5.1-2)

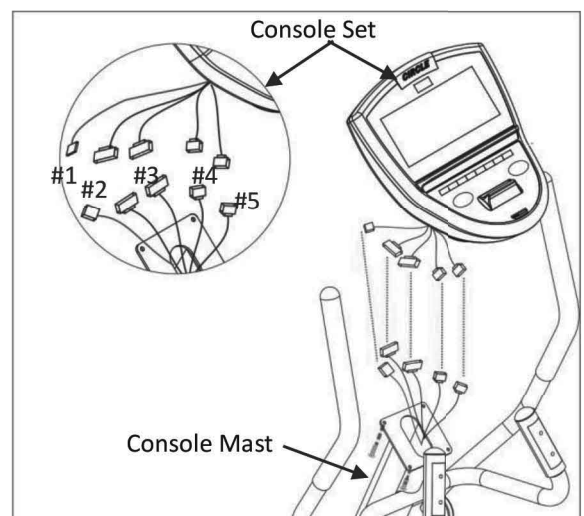

Fig 5.1-1

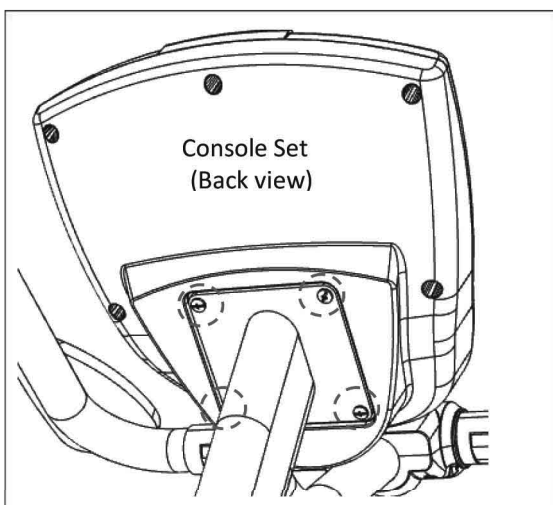

Fig 5.1-2

TABLE OF CONTENTS

TABLE OF CONTENTS	1
SAFETY PRECAUTIONS	2
TECHNICAL SPECIFICATIONS	3
UNPACKING & ASSEMBLY	4-9
WARM UP & COOL DOWN	10
PANEL CONTROL	11-12
PROGRAM	13-16
HOW TO USE THE TRAINER	17
PREVENTATIVE MAINTENANCE	18

Hint of how to dispose

- Do not dispose of electrical appliances as unsorted municipal waste, use separate collection facilities.
- Contact your local government for information regarding the collection systems available.
- If electrical appliances are disposed of in landfills or dumps, hazardous substances can leak into the groundwater and get into the food chain, damaging your health and well-being.
- When replacing old appliances with new once, the retailer is legally obligated to take back your old appliance for disposal at least for free of charge.



Descriptions & Specifications:

This Elliptical trainer is built in compliance with EN 957-1: 2005&EN 957-9: 2003 with maximum permissible user's weight of 150kg and classified as SA and equipped with speed independent braking system.

This training equipment is a stationary exercise machine used to simulate walking or running without causing excessive pressure to the joints, hence decreasing the risk of impact injuries.



















Elliptical trainers offer a non-impact cardiovascular workout that can vary from light to high intensity based on the resistance preference set by the user. It will work the your upper and lower body and increase cardio capacity and maintain fitness of your body also.

Before beginning any exercise program, consult your doctor.

This is especially important for people aged over 35 or who have previously had health problems, and those who have not done any sport for a number of years.

- Remark:
1. The classification of SA means this elliptical trainer is designed for studio use and with good accuracy class, the variations of power consuming are within $\pm 5W$ up to 50W and $\pm 10\%$ over 50W.
 2. The braking resistance level is adjustable by the controller, the power consumption is independent on the pedaling speed.

SAFETY PRECAUTIONS

-  WARNING: Read all instructions in this manual before use and keep this user's manual for entire life of this product for further reference.
-  WARNING: It is owner's responsibility to ensure that all users of this elliptical trainer are adequately informed about all safety precautions before use. Use the elliptical trainer only as described in this manual.
-  WARNING: Consult your physician before beginning any exercise program.
-  WARNING: Do not to use if you feel dizzy or have an acute cold or fever.
-  WARNING: To reduce the risk of serious injury, read the following safety precautions before using the exercise elliptical.
-  WARNING: Keep children under the age of 14 and pets away this trainer at all times. Before the training starts, remove all objects within a radius of 2 meters from the machine.
-  WARNING: Never insert objects into any opening in the exercise elliptical. If an object should drop inside, carefully retrieve it.
-  WARNING: Close supervision is necessary when this exercise elliptical is being used by or near children, or disabled persons.
-  WARNING: Warning up exercise is necessary before you start your training.
-  WARNING: Your health could be impaired by incorrect or excessive trainings. If you feel pain or dizziness while exercising, stop immediately and cool down then consult a doctor before beginning a planned training program.
-  WARNING: The pulse sensor is not a medical device. Various factors including the user's movement, may affect the accuracy of the heart rate readings. The Pulse sensor is intended only as an exercise aid in determining heart rate reads in general.
-  WARNING: Wear appropriate exercise clothing and when using the trainer. Do not wear loose clothing that could be caught by this trainer.
-  WARNING: Assemble the machine exactly as described in the installation instructions and use the enclosed parts contained in the parts& tool kits.
-  WARNING: Keep the exercise elliptical indoors, away from moisture and dust. Place the exercise elliptical on a stable & level surface, with a mat beneath it to protect the floor or carpet. Make sure that there is enough clearance around the exercise elliptical to mount, dismount, and use it.
-  WARNING: Inspect and properly tighten all parts regularly and. If any damages were found, keep the equipment out of use until repair and call our service center or the retailer for further helps.
-  WARNING: Always follow the console instructions for proper operation
-  WARNING: When mounting and dismounting the exercise elliptical, always hold the handlebars tightly when the elliptical trainer comes to rest then get off the pedal platform that is in the lowest position and land on the floor.
-  WARNING: When you stop exercising, allow the pedals to slowly come to a stop.
-  WARNING: Allow only one person at a time on your machine.

TECHNICAL SPECIFICATIONS

SPECIFICATIONS:

SPECIFICATIONS:

Dimensions : L: 2107 mmx W: 632 mmx H:1794 mm

Weight of product : 83.5kg (183.7 lbs)

Program : 6 preset programs , Fitness Test ,HRC*4

Standard features: 8*16dot matrix HR receive

Resistance System : EMS(Eddy Current Magnet System)

Power source : Built-in generator & rechargeable battery 12V-1.2AH

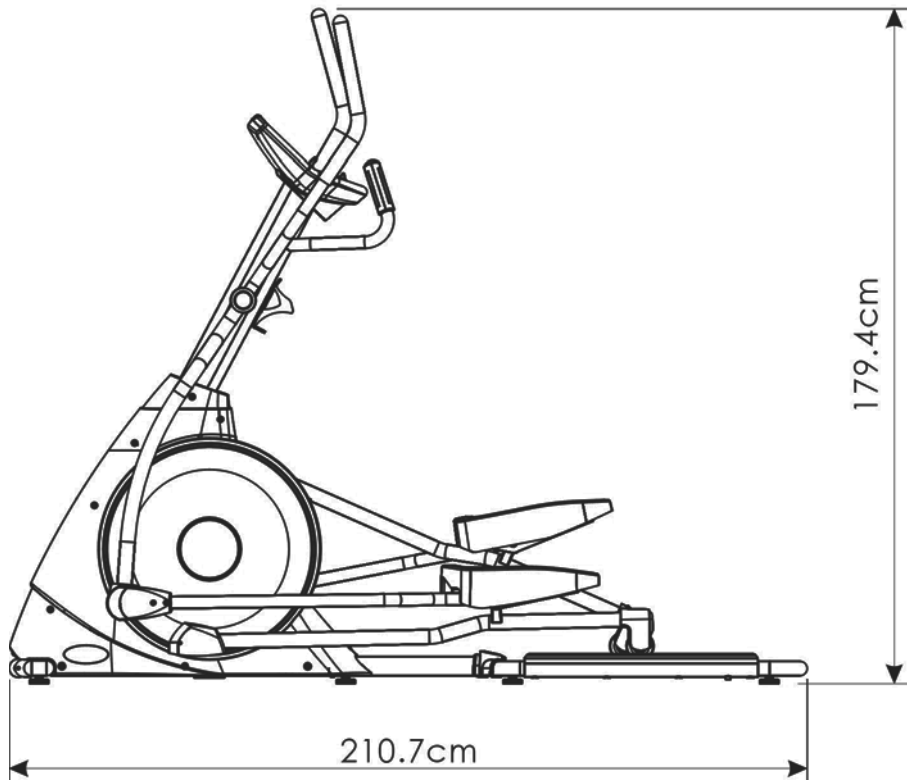
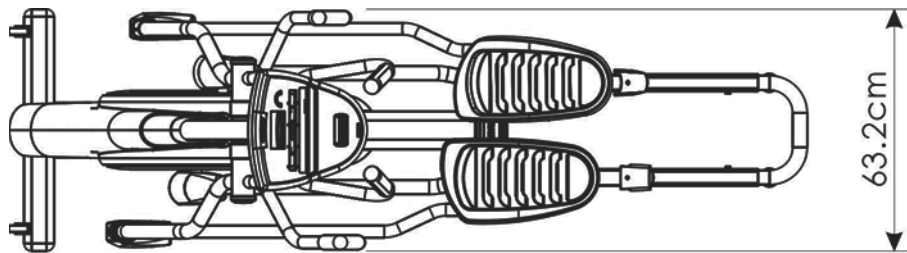

UNPACKING & ASSEMBLY

PARTS

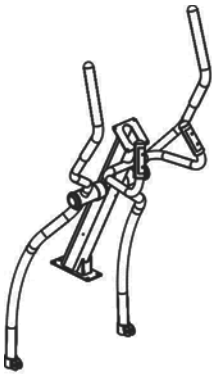

Handle bar set

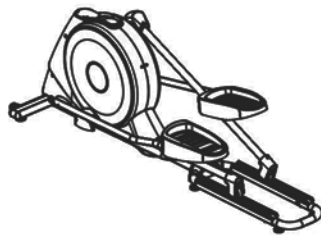

Housing

#6-19



Console set

#6-17



#6-18



Console frame cover

#6-12

#6-13



Left cover, right arm
Right cover, right arm

#6-10

#6-11

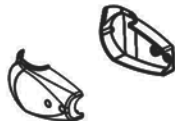

Left cover, left arm
Right cover, left arm





#6-1



Bottle Holder

UNPACKING & ASSEMBLY

HARDWARE KIT

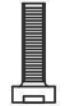
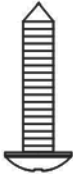
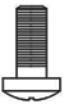
Step1	 <p>#6-7 M8*20mm /4pcs (Handle bar set)</p>	 <p>#6-8 M8 S washer / 4pcs (Handle bar set)</p>	 <p>#6-9 M8 washer / 4pcs (Handle bar set)</p>	
	 <p>#6-3 M4*10mm /2pcs (Console frame cover)</p>	 <p>#6-4 M4*12mm /2pcs (Console frame cover)</p>		
Step4	 <p>#6-5 M4*12mm / 8pcs (Left / right cover)</p>	 <p>#6-6 M3*30mm / 2pcs (Left / right cover)</p>	Step5	 <p>#6-2 M5*12mm / 4pcs (Console set)</p>

Allen wrench /
1pc(3mm)

Allen wrench /
1pc(4mm)

Allen wrench /
1pc(5mm)

Allen wrench /
1pc(6mm)



1pc

UNPACKING & ASSEMBLY

TO avoid components damage, please unpacking carton carefully, we suggest you to put a pad on the floor before you put the elliptical down.

Step1.Assemble Handle bar set on the housing.

NOTE! It might need 2~3 persons to assembly!

- 1).put handle bar post into main frame , connected upper console wire and lower console wire.
- 2).Using 4pcs of M8*20mm screw 、washer and S washer , fixing handle bar post and main frame.
- 3).Using 2pcs of M4*12mm screw , fixing the console frame cover and main frame.

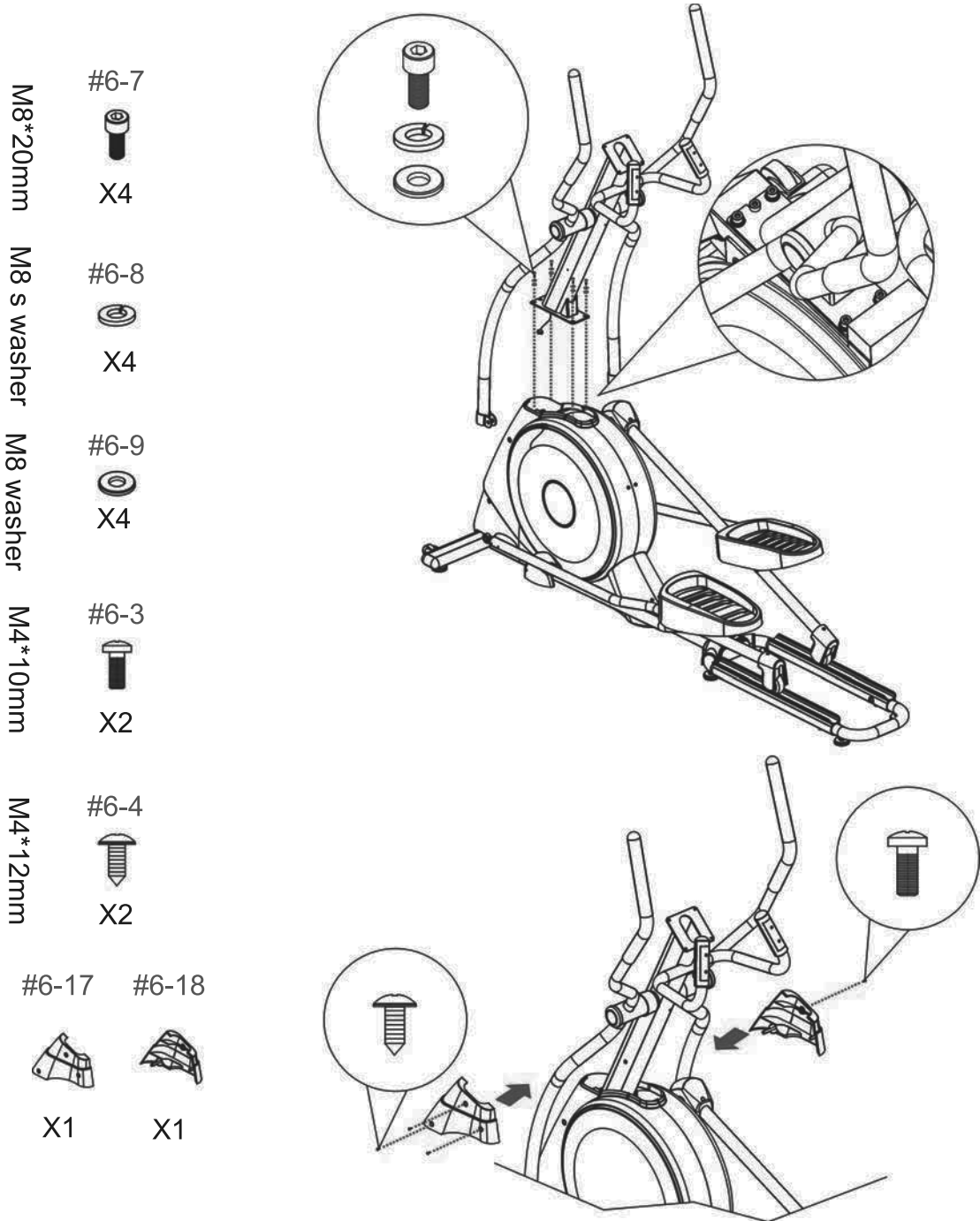

UNPACKING & ASSEMBLY

Step2.Assemble Bottle Holder on the handle bar set.

1).Using 2pcs of M5*10mm screw , fixing the bottle holder on the handle bar post .

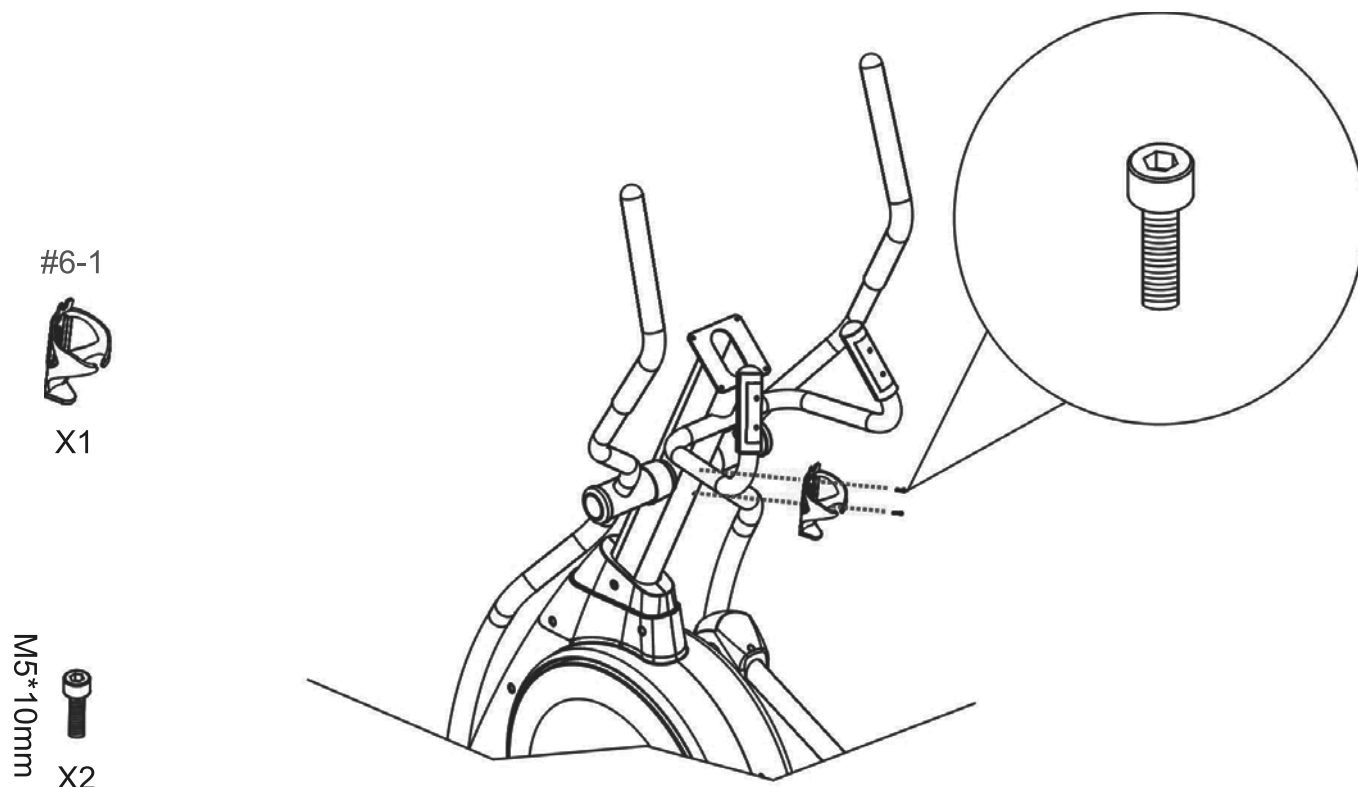

UNPACKING & ASSEMBLY

Step 3. Assembly Handle arm on the Pedal linkage.

1). Use 2x M8*23mm screws, M8 washer and M8*16mm screws to fasten Handle arm and Pedal linkage.

M8*23mm #6-14
X2

M8 #6-15
X2

M8*16mm #6-16
X2

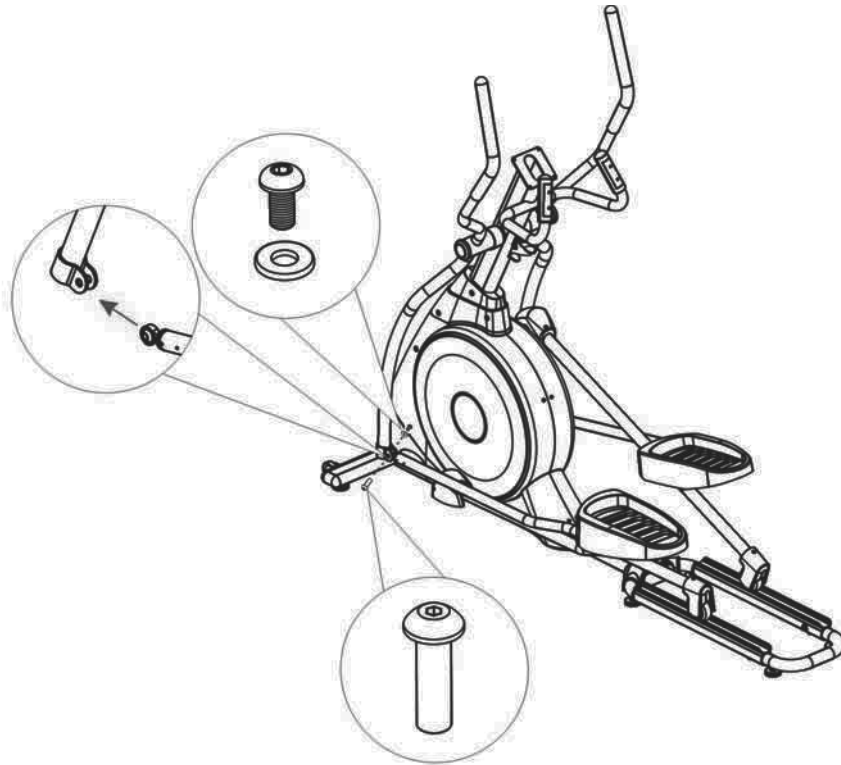

Step 4. Assembly Left / right cover on the Pedal Linkage.

1). Assemble right/left arm cover with pedal arm.

2). Fasten 4pcs M4x12mm screws on left/right arm cover by 5mm wrench.

3). Fasten 1pcs M3x30mm screw on left/right arm cover by 3mm wrench.

M3*30mm #6-6
X2

M4*12mm #6-5
X8

#6-12 #6-13

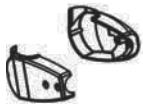

X1set

#6-10 #6-11



X1set

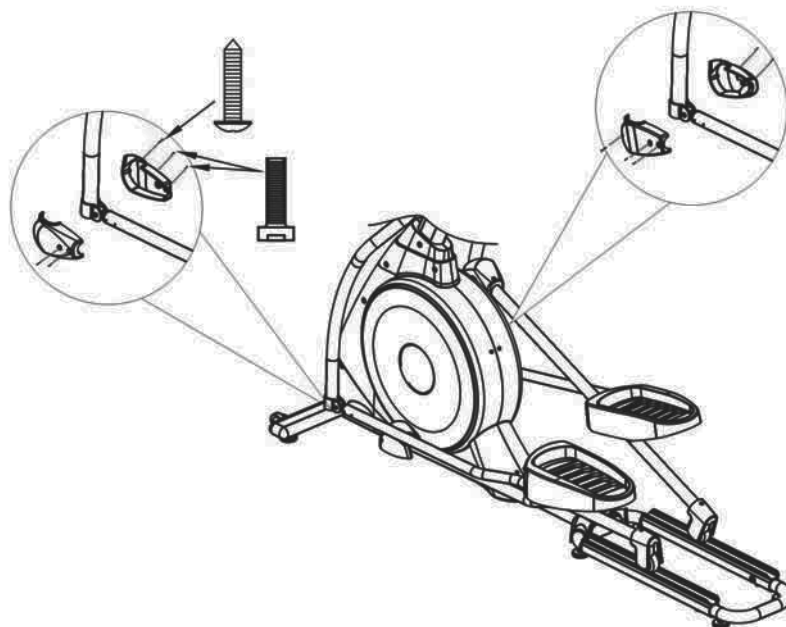

UNPACKING & ASSEMBLY

Step5: Assembly console with handle bar post

- 1).Put the console into handle bar post , connected upper console wire with lower console wire.
- 2).Using 4pcs of M5*12mm screw , tighten all screws.

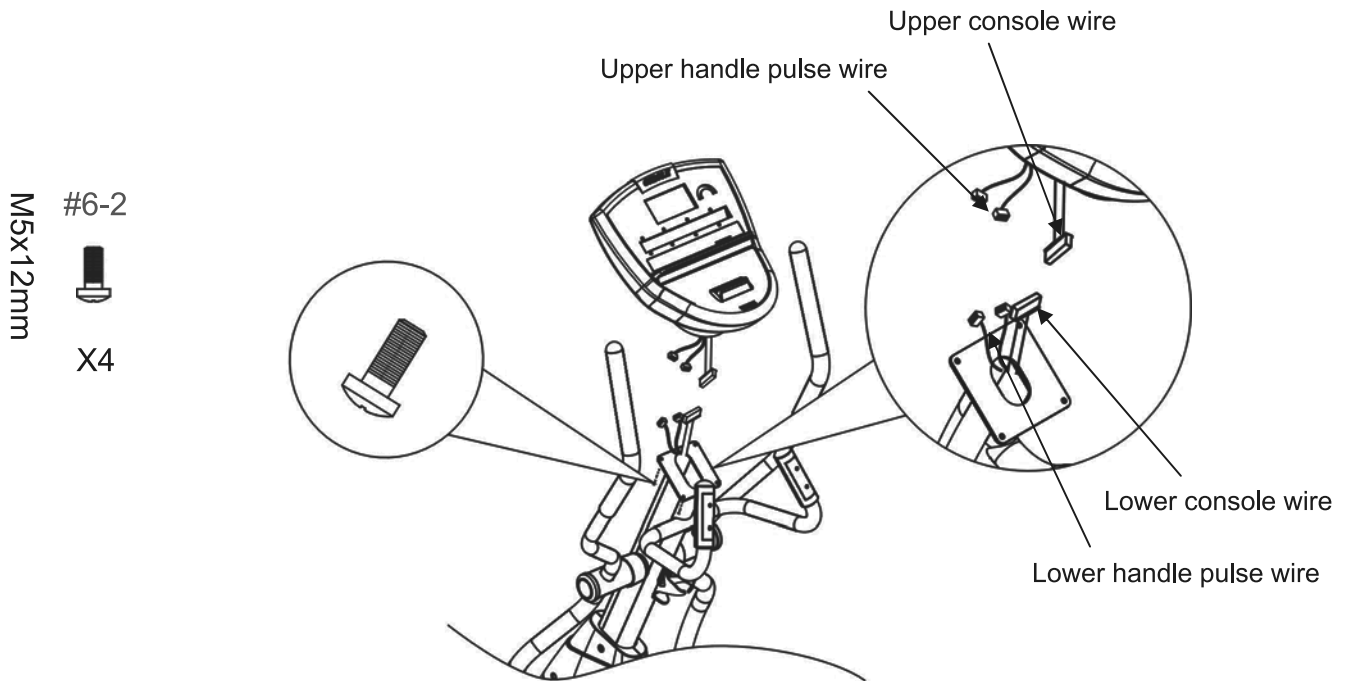

WARM UP & COOL DOWN

A successful exercise program consists of a warm up, aerobic exercise and a cool down. Warming up is an important part of your workout, and should begin every session. It prepares your body for more strenuous exercise by heating up and stretching out your muscles. At the end of your workout, repeat these exercises to reduce sore muscle problems. We suggest the following warm-up and cool-down exercises:



HEAD ROLLS

Rotate your head to the right for one count, feeling the stretch up the left side of your neck. Next rotate your head back for one count, stretching your chin to the ceiling and letting your mouth open. Rotate your head to the left for one count, and finally, drop your head to your chest for one count. Repeat this action for several times.



SHOULDER LIFTS

Lift your right shoulder up toward your ear for one count. Then lift your left shoulder up for one count as you lower your right shoulder. Repeat this action for several times.



QUADRICEPS STRETCH

With one hand against a wall for balance, reach behind you and pull your right foot up. Bring your heel as close to your buttocks as possible. Hold for 15 seconds and repeat with left foot up.



SIDE STRETCHES

Open your arms to the side and continue lifting them until they are over your head. Reach your right arm as far upward toward the ceiling as you can for one count. Feel the stretch up your right side. Repeat this action with your left arm.



CALF/ACHILLES STRETCH

Step your right foot in front of your body. Lean against a wall with your arms and stretch your left foot backward your body. Bend forwards your right foot, and slightly push your buttock toward to the wall for 15 seconds. Repeat the action with front left foot and rear right foot for another 15 seconds.



INNER THIGH STRETCH

Sit with the soles of your feet together with your knees pointing outward. Pull your feet as close into your groin as possible. Gently push your knees toward the floor. Hold for 15 seconds. Repeat this action 3-5 times.

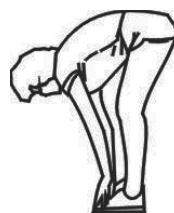

TOE TOUCHES

Slowly bend forward from your waist, letting your back and shoulder relax as you stretch toward your toes. Reach down as far as you can and hold for 15 seconds.



HAMSTRING STRETCHES

Keep your right leg straight and the left foot on the floor; try to stretch your right hand toward the toe, hold this posture for 15 seconds. Relax, then repeat the action for left leg.

PANEL CONTROL

Display & Keys

Dot-matrix, display program profiles & message

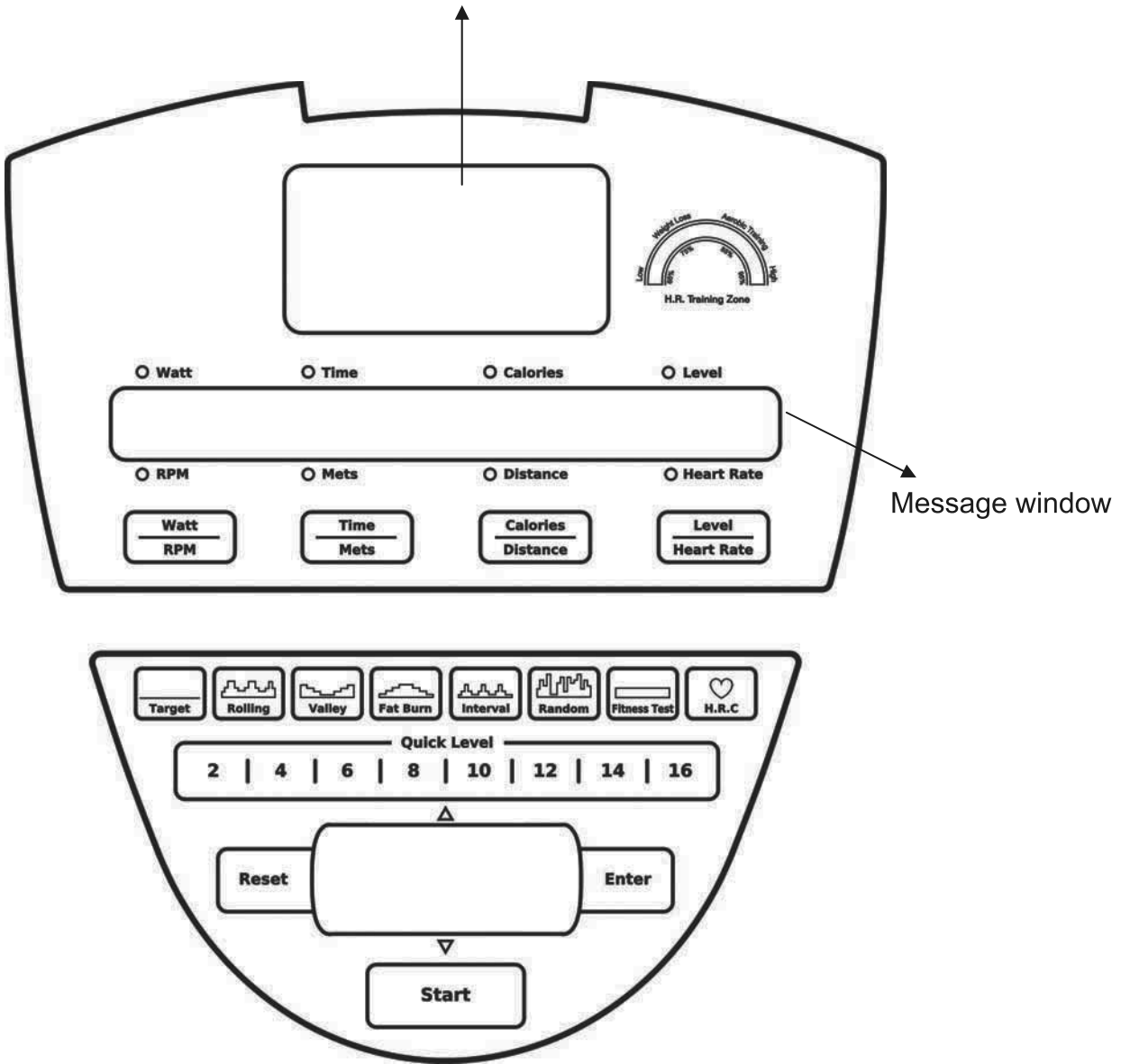

PANEL CONTROL

Display function

Display	Defination
Time	Displays time remaining or total time.
Calories	Displays calories burned.
Heart Rate	Displays hand grip and wireless Heart Rate reading.
Distance	Displays total distance KM/Mi.
RPM	Displays pedaling RPM.
Watts	Displays consuming watt.
Mets	Displays the multiple of rest.
Level	Displays current resistance level L1~L16

※ Calories & Heart Rate for reference only.

Key function

Key	Function
Start	Quick start or program start.
▲	Adjust workload up.Adjust value when program setting. Select program
▼	Adjust workload down.Adjust value when program setting. Select program
Display	RPM←→Watt Calories←→Distance Time←→Mets Level←→Heart Rate
Enter	Confirm value entered.
Rest	Reset back to idle mode while pause
Progarm	Select program directly
Keypad	Set value

PROGRAM

PROGRAMS DESCRIPTION

1. QUICK START

- 1.1 To pedal over 30 rpm to wake up and initial the system to idle mode, press 『 START 』 to quick start.
- 1.2 Press shift UP or DOWN to exercise level by 1 level or press quick Level Key to change level.
- 1.3 Stop pedaling will pause the system, stop pedaling over 30 seconds system will auto shut down.

2. Target

2.1. Press 『 Target 』 key to enter the program.

- 2.1.1. Set time : use shift up or down device to set time then press 『 ENTER 』 to next settings.
- 2.1.2. Set weight: use shift up or down device to set weight then press 『 ENTER 』 to next settings.
- 2.1.3. Set age: use shift up or down device to set age then press 『 ENTER 』 to next settings.
- 2.1.4. Set distance: use shift up or down device to set distance then press 『 ENTER 』 to next settings.
- 2.1.5. Set calories: use shift up or down device to set calories then press 『 START 』 to begin workout.

2.2. Beginning the workout:

- 2.2.1. If either, Time, Distance and Calories are set the program will count down. Once the preset value reaches 0 the program will end. If no goal is set the program will not end unless manually stopped.

3. Preset program :

3.1. There are 5 preset programs, ROLLING, VALLEY, FAT BURN, INTERVAL, RANDOM. Press their own program key to enter the program.

- 3.1.1. Set time : use shift up or down device to set time then press 『 ENTER 』 to next settings.
- 3.1.2. Set weight: use shift up or down device to set weight then press 『 ENTER 』 to next settings.
- 3.1.3. Set age: use shift up or down device to set age then press 『 ENTER 』 to next settings.
- 3.1.4. Set workout level: use shift up or down device to set level 1~5(For RANDOM program will change the profile randomly. Press 『 START 』 to begin workout.

3.2. Beginning the workout:

3.2.1. The resistance level will change automatically according to the program settings, the resistance level will change every 2 minutes per segment if the time is in count up mode, if time is entered during setup then the segment time=set time / 16. You can use any speed or incline key to change speed or incline during your workout.

3.2.2. The program will end when the counter reaches 0.

3.2.3. Preset program profiles:

P1=ROLLING 、 P2=VALLEY 、 P3=FAT BURN 、 P4=INTERVAL 、 P5= RANDOM

P	SEG	1	2	3	4	5	6	7	8	9	10	11	12	13	14	15	16
P1	LEVEL 1	4	6	8	8	6	4	4	6	8	8	6	4	4	6	8	6
	LEVEL 2	5	6	8	9	9	8	6	6	7	9	8	7	6	6	7	8
	LEVEL 3	7	8	9	10	10	8	8	6	8	10	10	9	8	6	8	10
	LEVEL4	9	10	11	13	10	8	11	13	10	9	8	10	11	13	10	9
	LEVEL5	11	13	15	15	13	11	11	13	15	15	13	11	11	13	15	12
P2	LEVEL 1	8	8	6	6	4	4	2	2	2	2	4	4	6	6	8	8
	LEVEL 2	9	6	5	4	3	2	2	4	6	6	7	10	10	11	11	12
	LEVEL 3	11	10	10	8	7	6	5	4	3	3	5	5	7	10	10	13
	LEVEL4	13	12	12	10	9	8	6	6	6	7	8	9	10	12	12	14
	LEVEL5	15	15	12	12	10	10	8	8	8	8	10	10	12	12	15	15
P3	LEVEL 1	2	2	4	4	6	6	8	8	8	8	6	6	4	4	2	2
	LEVEL 2	3	5	5	7	8	9	10	10	11	12	10	10	7	6	3	3
	LEVEL 3	5	6	7	7	9	10	10	12	12	12	10	10	8	8	5	5
	LEVEL4	6	6	8	8	11	11	13	14	14	12	10	10	9	8	6	6
	LEVEL5	8	8	10	10	12	12	15	15	15	15	12	12	10	10	8	8
P4	LEVEL 1	2	4	8	4	2	2	4	8	4	2	2	4	8	4	2	2
	LEVEL 2	3	5	8	6	1	1	5	7	6	3	3	3	6	6	4	3
	LEVEL 3	5	7	9	9	6	5	4	4	4	6	7	8	10	8	6	6
	LEVEL4	7	8	10	10	12	12	10	10	8	8	10	12	12	10	8	8
	LEVEL5	8	10	15	10	8	8	10	15	10	8	8	10	15	10	8	8

PROGRAM

4. HRC(Heart Rate Control)

- 4.1. Press 『H.R.C』 key to enter the program.
- 4.2. Set time : use shift up or down device to set time then press 『ENTER』 to next settings.
- 4.3. Set weight: use shift up or down device to set weight then press 『ENTER』 to next settings.
- 4.4. Set age: use shift up or down device to set age then press 『ENTER』 to next settings.
- 4.5. Set workout mode: There are 3 types of HRC mode. 『WEIGHT LOSS MODE』, 『AEROBIC MODE』, 『TARGET MODE』, use shift up or down device to select the desired HRC type then press 『ENTER』 to next settings.
- 4.6. Set target heart rate: use shift up or down device to set Target Heart Rate(WEIGHT LOSS MODE default value=MHR 70%, setting range=MHR 66%~75%. AEROBIC MODE default value=MHR 80%, setting range=MHR 76%~85%, TARGET HEART RATE default value=130, setting range=100~180) then press 『ENTER』 to next settings.
- 4.7. Set begin resistance level: use shift up or down device to set LEVEL then press 『START』 to begin workout.
- 4.8. Beginning the workout:
 - 4.8.1 The program will compare the real time and preset target heart rate every 30 seconds to adjust resistance level until the actual heart rate is reaches with in + or – 5 beats of the preset target heart rate.
 - 4.8.2 During the program, if the actual pulse rate \leq target workout heart rate minus 5, the resistance level will be increased one level every 30 seconds until the max. level.
 - 4.8.3 During the program, if the actual pulse rate \geq target workout heart rate plus 5, the resistance level will be decreased one level every 30 seconds until the min. level.
 - 4.8.4 You can use any resistance level key or device to change the resistance level during your workout.
 - 4.8.5 The program will end when the counter reaches 0.

PROGRAM

5. Fitness Test :

5.1. Press 『Fitness Test』 key to enter the program.

5.2. Set weight: use shift up or down device to set weight then press 『ENTER』 to next settings.

5.3. Set age: use shift up or down device to set age then press 『START』 to begin workout.

5.4. Beginning the workout:

5.4.1. There are 10 stages at most, 3 minutes per stage, first stage(0~3 min) the wattage preset value=55W, the preset wattage value from stage 2~10 depend on average heart rate value of first stage, shown as below:

2:01-3:00 AVG. HR Stage	< 80bpm	80-89bpm	90-100bpm	>100bpm
2 - (3:01~6:00)	125W	100W	75W	55W
3 - (6:01~9:00)	150W	125W	100W	75W
4 - (9:01~12:00)	175W	150W	125W	100W
5 - (12:01~15:00)	200W	175W	150W	125W
6 - (15:01~18:00)	225W	200W	175W	150W
7 - (18:01~21:00)	250W	225W	200W	175W
8 - (21:01~24:00)	-----	250W	225W	200W
9 - (24:01~27:00)	-----	-----	250W	225W
10 - (27:01~30:00)	-----	-----	-----	250W

5.4.2. Can not adjust the resistance level manual, program will auto change the level according to the preset rules.

5.4.3. The program will end while heart rate value reach or over MHR 85% - 10 for 10 seconds. The program will show you the VO2 MAX value.

MOVING

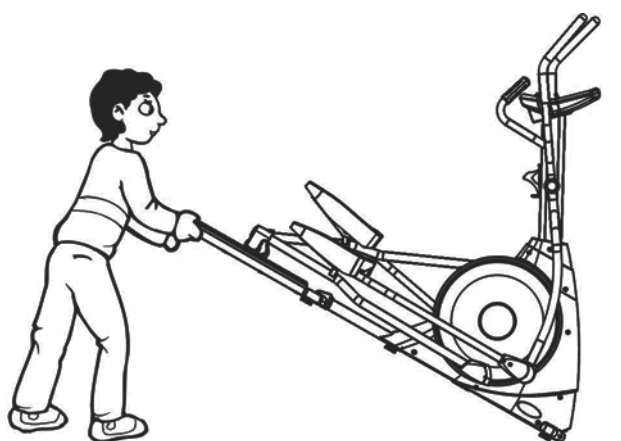

HOW TO USE THE TRAINER

How to Mount and Dismount the Trainer



Hold swing bars & step forward and backward.



Hold handlebars on post & step forward and backward.



PREVENTATIVE MAINTENANCE

F833718-000-00 EP-6001A2 10705

HOW TO CARE FOR YOUR ELLIPTICAL

The Safety of the equipment can be maintained only if the equipment is examined regularly for damage or wear. If maintenance is required, keep the equipment out of use until defective parts are repaired or replaced.

Pay special attention to parts that are subject to wear as outlined in the *Preventative Maintenance Schedule*.

The following preventive maintenance will keep the exercise elliptical operating at peak performance :

- Locate the exercise elliptical in a cool, dry place.
- Clean the top surface of the pedals regularly.
- Keep the display console free of fingerprints and salt build-up caused by sweat.
- Use a 100% cotton cloth, lightly moistened with water and mild liquid cleaning product, to clean the exercise elliptical other fabrics, including paper towels, may scratch the surface. Do not finger to press the selection buttons on the console.
- Clean the housing thoroughly on a regular basis.

NOTE :

Before use the elliptical, please make sure the Aluminum tracks are cleaned and lubricated, this is to prevent the damage and noise on tracks when you are exercising.

The exercise elliptical can be wiped clean with a soft cloth and mild detergent. **Do not use abrasives or solvents.** To prevent damage to the console, keep liquids away from the console and keep the console out of direct sunlight.

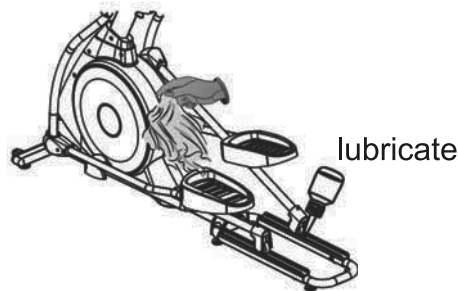
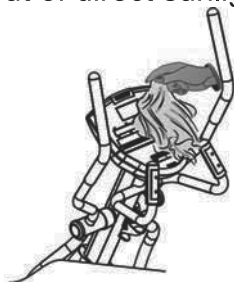

Preventative Maintenance Schedule

Follow the schedule below to ensure proper operation of the product.

ITEM	WEEKLY	MONTHLY	BI-ANNUALLY	ANNUALLY
Display Console	C	I		
Console Mounting Bolts			I	
Accessory Tray	C	I		
Frame	C			I
Plastic Covers	C	I		
Pedals and Straps	C	I		
KEY : C=Clean; I=Inspect				

Hand pulse

Before/after running, to put your feet separately on each side rein, then hold the hand grip, so as to avoid any shaking. If the heart beat is too high or irregular, please have your hands out of the hand grip until the pulse display returns to " 0 ", then redoing the test.

Don't do this test while running.

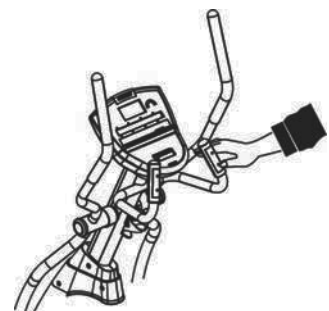

PART B

Console Operation

***FOR MODEL:
B8 S Upright Bike
R8 S Recumbent
E7 S Elliptical
B6 S Upright Bike
R6 S Recumbent
E6 S Elliptical***

TABLE OF CONTENTS

CIRCLECLOUD GO	B-3
1. CONSOLE OVERVIEW	B-4
1.1 Console of B8 S Upright Bike, R8 S Recumbent and E7 S Elliptical	B-4
1.2 Console of B6 S Upright Bike, R6 S Recumbent and E6 S Elliptical	B-5
1.3 Engineering Mode Setting	B-6
2. TOUCH SCREEN OVERVIEW	B-7
2.1 HOME Screen	B-7
2.2 LANGUAGE SELECTION	B-9
2.3 LOG IN	B-10
2.4 SETTINGS	B-15
2.5 FORGOT PASSWORD	B-18
2.6 CIRCLECLOUD GO SIGN UP	B-19
2.7 TRAINING	B-20
2.8 HEART RATE CONTROL	B-27
2.9 TARGET TRAIN	B-31
2.10 MY PERFORMANCE	B-38
2.11 BODY MANAGER	B-40
2.12 MY GYM	B-41
2.13 MY WORKOUT	B-44

CIRCLECLOUD GO

CircleCloud Go is a comprehensive wellness eco-system aimed to deliver most effective body and fitness management. With unique apps developed or popular apps intergated reaching your desired fitness goal.

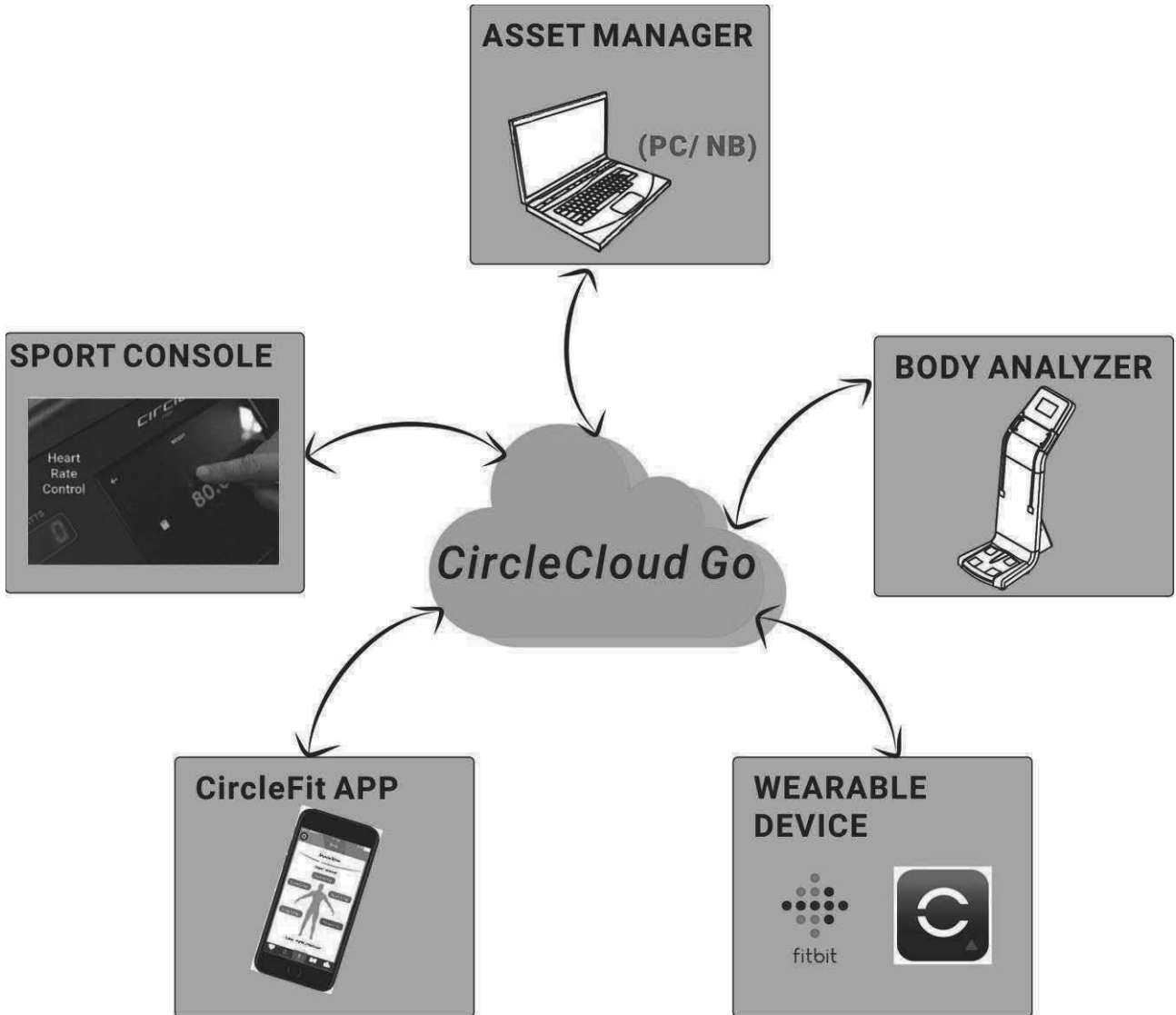

1. CONSOLE OVERVIEW

1.1 Console of B8 S Upright Bike, R8 S Recumbent and E7 S Elliptical

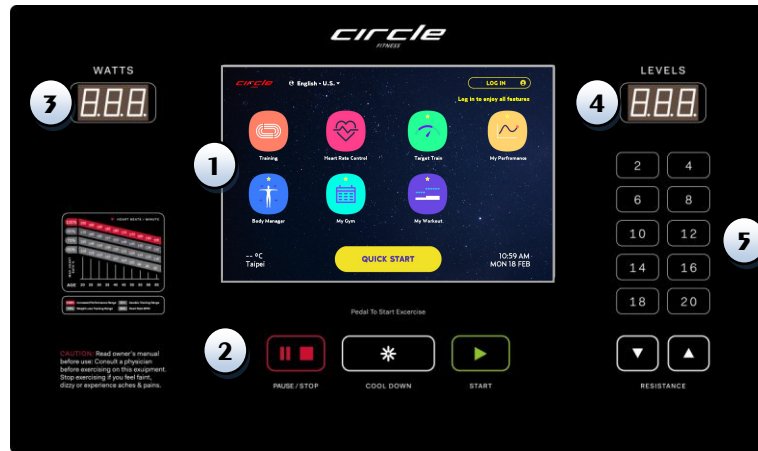

No	Display / Button	Descriptions
1	8 inch Touch Screen	Tap to select, set up, monitor and save workouts.
2	PAUSE/ STOP	Tap once to pause an active workout. Tap twice to end a paused workout.
	COOL DOWN	Tap to gradually lower speed of the program.
	START	Tap to start the program.
	FAN (OPTION)	Tap to turn the fan on. There are two fan speeds (low and high).
3	WATTS 888	Displays the consuming watts.
4	LEVELS 888	Displays the current resistance level.
5	Quick Resistance Buttons (2/ 4/ 6/ 8/ 10/ 12/ 14/ 16/ 18/ 20)	Tap the one of quick resistance button for quick adjust resistance to a predetermined value.
	Resistance Arrow Buttons (▲/▼)	Use the arrow keys to adjust the resistance.

NOTE: If the operation system has crashed or skipped to Android desktop, please restart the equipment.

1.2 Console of B6 S Upright Bike, R6 S Recumbent and E6 S Elliptical

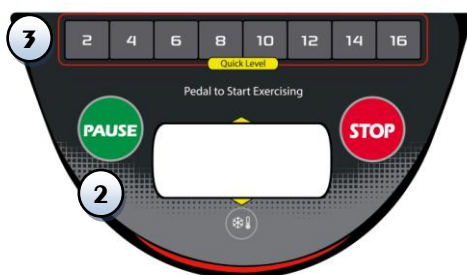

No	Display / Button	Descriptions
1	8 inch Touchscreen	Tap to select, set up, monitor and save workouts.
2	PAUSE	Tap to pause an active workout.
	STOP	Tap to end a paused workout.
	COOL DOWN	Tap to gradually lower speed of the program.
	START	Tap to start the program.
	FAN (OPTION)	Tap to turn the fan on. There are two fan speeds (low and high).
3	Quick Resistance (2/4/6/8/10/12/14/16) & Resistance Arrow Buttons (+/-)	Tap the one of quick resistance button for quick adjust resistance to a predetermined value. Use the arrow keys to adjust the resistance; Adjusts program types and program values.
4	USB Port	Charge USB devices.

NOTE: If the operation system has crashed or skipped to Android desktop, please restart the equipment.

1.3 Engineering Mode Setting

This console features an engineering mode that allows you to view usage information, to personalize console settings, and to set up and manage a wireless network connection.

NOTE: Before operating the console, make sure that the power cord is properly plugged in.

Get into Engineering Mode



Press and hold the upper-right corner on **HOME Screen** for 5 seconds to get into Engineering Mode.

Engineering Mode - WIFI Setting

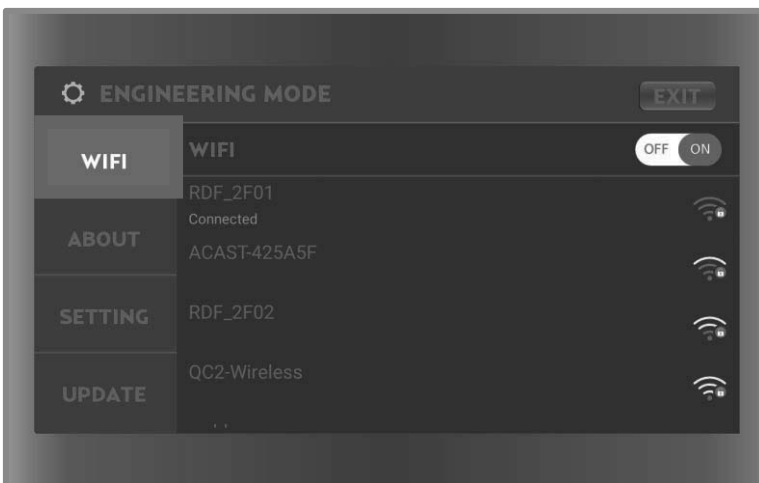

WIFI ON/OFF

Slide the **ON/OFF** button to enable/disable WIFI connection.

When WIFI is enabled, the screen will display a list of available networks.

NOTE: It may take several seconds for the list of wireless networks to appear.

To connect to a network, just click on its name. If it's a secure network and it's the first time you've used it, you'll need a password.

Exit the Engineering Mode

Tap **EXIT** to skip to HOME Screen.

2. TOUCH SCREEN OVERVIEW

2.1 HOME Screen



No	Display / Button	Descriptions
1	WEATHER AND REGION DISPLAY	WEATHER: displays the tempature and weather icon if network is available. REGION: displays the region according to the engineering mode setting.
2	TIME AND DATE DISPLAY	TIME: Displays the time zone according to the engineering mode setting. DATE: displays the date and day.
3	QUICK START	Tap to immediately begin a workout.
4	LANGUAGE SELECTION	Tap to display LANGUAGE SELECTION Screen.
5	LOG IN	Tap to LOG IN Screen.

2.1 HOME Screen (Continued)



No.	Display / Button	Descriptions
6	TRAINING	We offer comprehensive cardio conditioning courses to help boost aerobic fitness and train your body.
7	HEART RATE CONTROL	Heart Rate Control maintains the heartbeats per minutes you select by controlling the exercise speed and intensity of your cardio equipment to optimize your workout.
8	TARGET TRAIN	Provide 5 different exercise targets, keeping you motivated and on track for your fitness plan.
9	MY PERFORMANCE	Integrated to cardio equipment, outdoor fitness apps or wearable devices together to give you the personal fitness information.
10	BODY MANAGER	To measure and track your body fitness via Circle Fitness IBA or InBody 570 and CircleFit wellness app.
11	MY GYM	Gives you the latest news, classes and offers from your facility.
12	MY WORKOUT	Provides you with the capability to design your own training course, tailored to suit your needs.

2.2 LANGUAGE SELECTION

Go to HOME Screen > SELECT LANGUAGE Screen

Preset language displays on the current screen. You can switch and set a language during a workout.



Tap the language icon to pop out a **SELECT LANGUAGE Screen** as below.

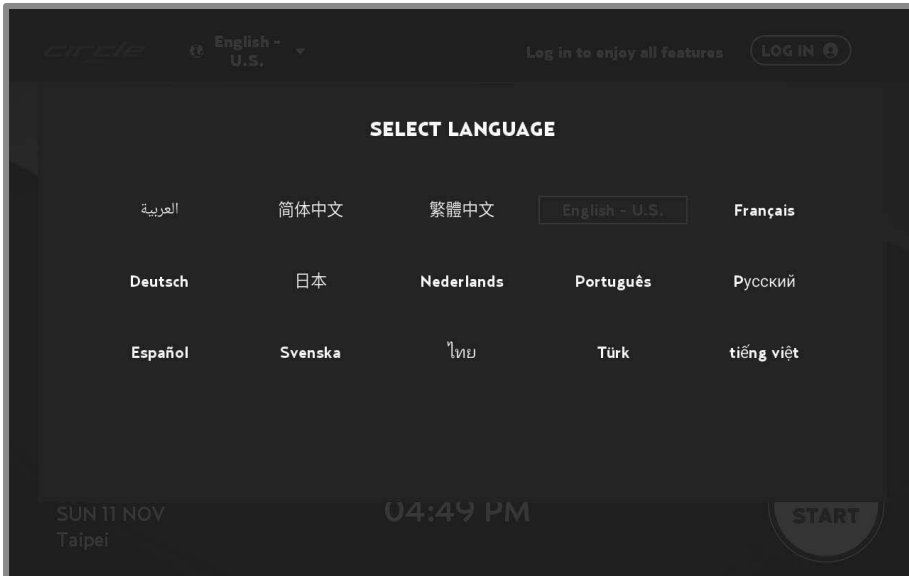

15 Language Options

Tap one of the languages to use during a workout.

After a selection is made, the language is saved, the **SELECT LANGUAGE Screen** is closed and the **HOME Screen** appears in the selected language.

2.3 LOG IN

Go to HOME Screen > LOG IN Screen

Two login methods are provided for you to select:

- 1) Log In Manually (Email Login).
- 2) Quick Login with CIRCLEFTIT app.

2.3.1 Log In Manually (Email Login)

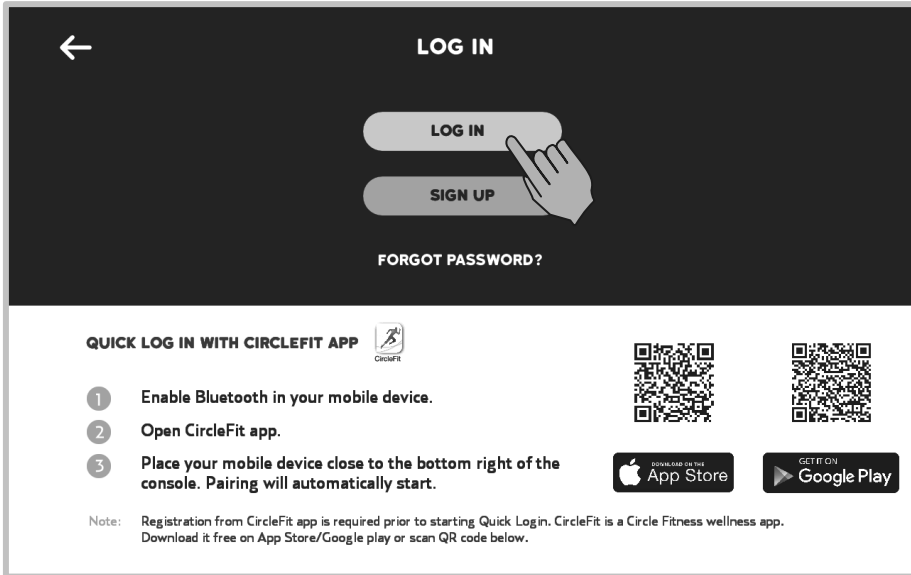

} Log in manually

Enter your EMAIL and PASSWORD via on-screen keyboard.

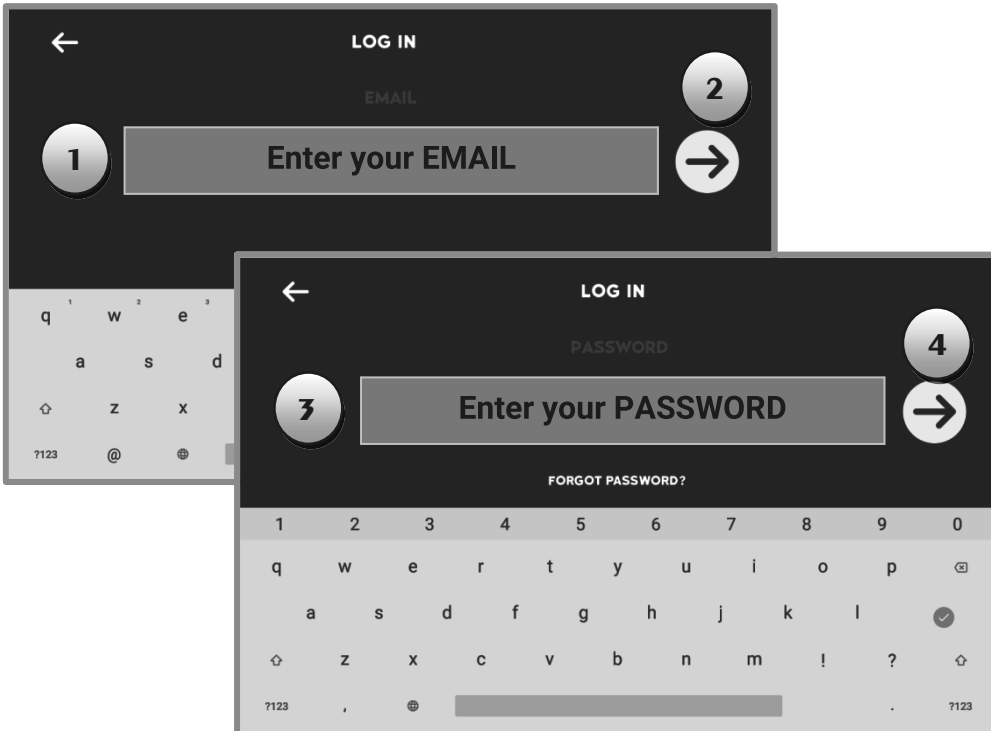

2.3 LOG IN (Continued)

2.3.2 Quick Login with CIRCLEFIT app

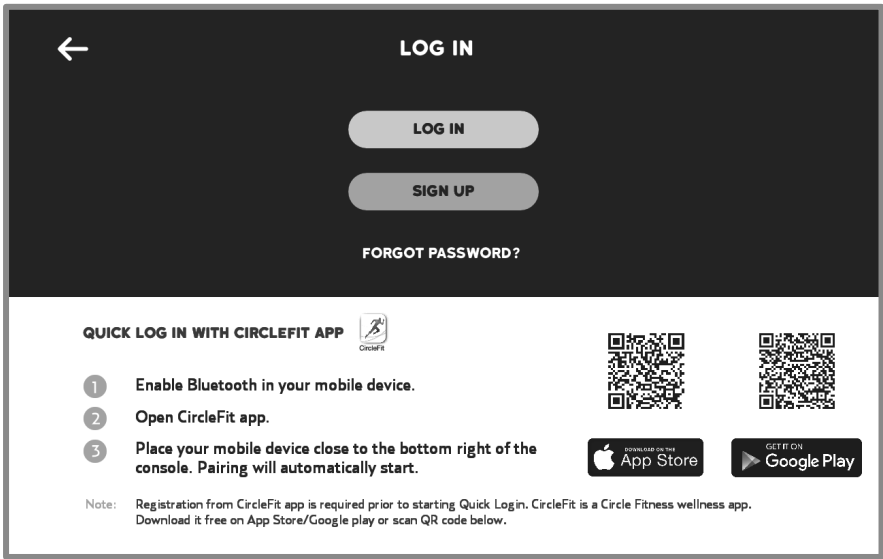

Quick Login with CIRCLEFIT app

Follow the steps to Quick Login:

- 1 Enable Bluetooth in your mobile device.
- 2 Open CircleFit app.
- 3 Place your mobile device close to the bottom of the console. Pairing will automatically start.

Note: Registration from CircleFit app is required prior to starting Quick Login. CircleFit is a Circle Fitness wellness app. Free download it on App Store/ Google Play or scan QR code below.



Once log in is succeed, the screen will displayed as below.



2.3.3 TUTORIAL

Tutorial shows a few tips to help you to get started. It displays as below when initial login is successful. (**Secondary login will not display the TUTORIAL Screens.**)

TUTORIAL > INTRO >



Scroll the touchscreen to access the next page.

TUTORIAL > INTRO > TARGET TRAIN



Set fitness targets with "Target Train"!

Scroll the touchscreen to access the next page.

2.3.3 TUTORIAL (Continued)

TUTORIAL > INTRO > TARGET TRAIN > MY PERFORMANCE



Measure your results with "My Performance".

Scroll the touchscreen to access the previous/ next screen.

INTRO > TARGET TRAIN > MY PERFORMANCE > BODY MANAGER

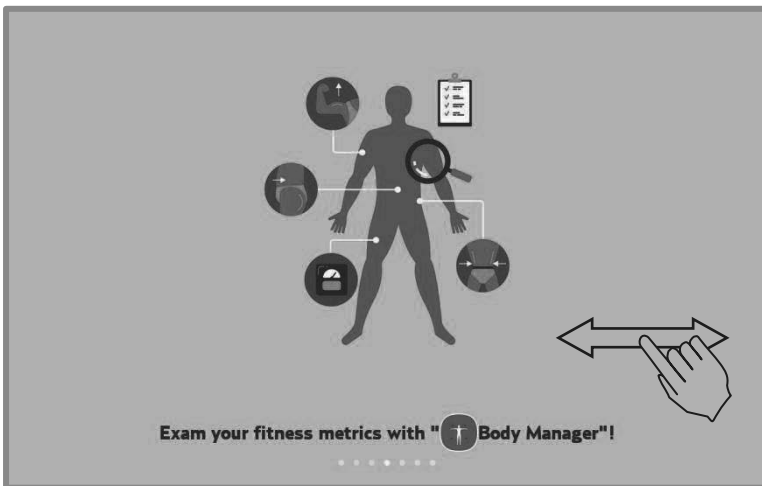

Exam your fitness metrics with "Body Manager".

Scroll the touchscreen to access the previous/ next screen.

MY PERFORMANCE > BODY MANAGER > MY GYM PAGE

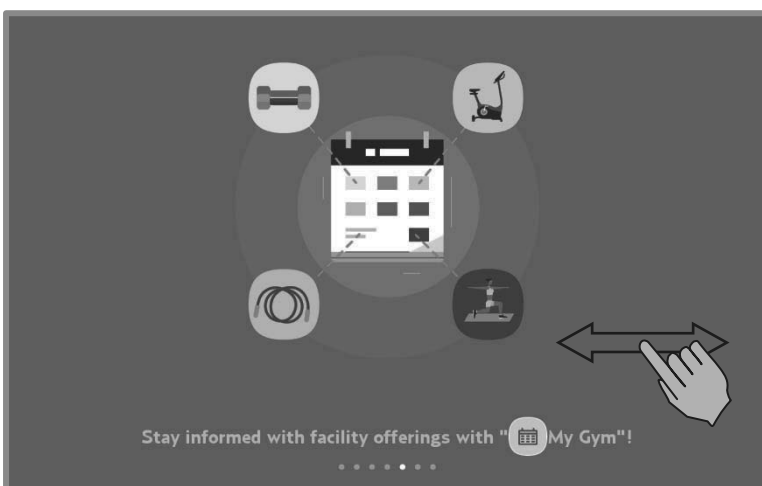

Stay informed with facility offerings with "My Gym".

Scroll the touchscreen to access the previous/ next screen.

2.3.3 TUTORIAL (Continued)

BODY MANAGER > MY GYM > MY WORKOUT



Create personalized workouts by using "My Workout"!

Scroll the touchscreen to access the previous/ next screen.

BODY MANAGER > MY GYM > MY WORKOUT > READY TO START PAGE

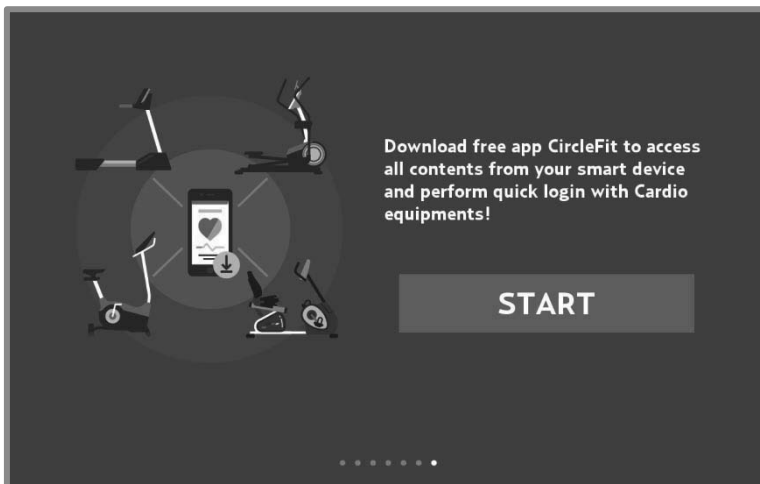

Download free CircleFit app to access all contents from your smart device and perform quick login with cardio equipment!

Tap **START** to end the Tutorial pages and skip to HOME Screen.

2.4 SETTINGS

Go to HOME Screen > LOGGED IN > SETTINGS > PROFILE Screen

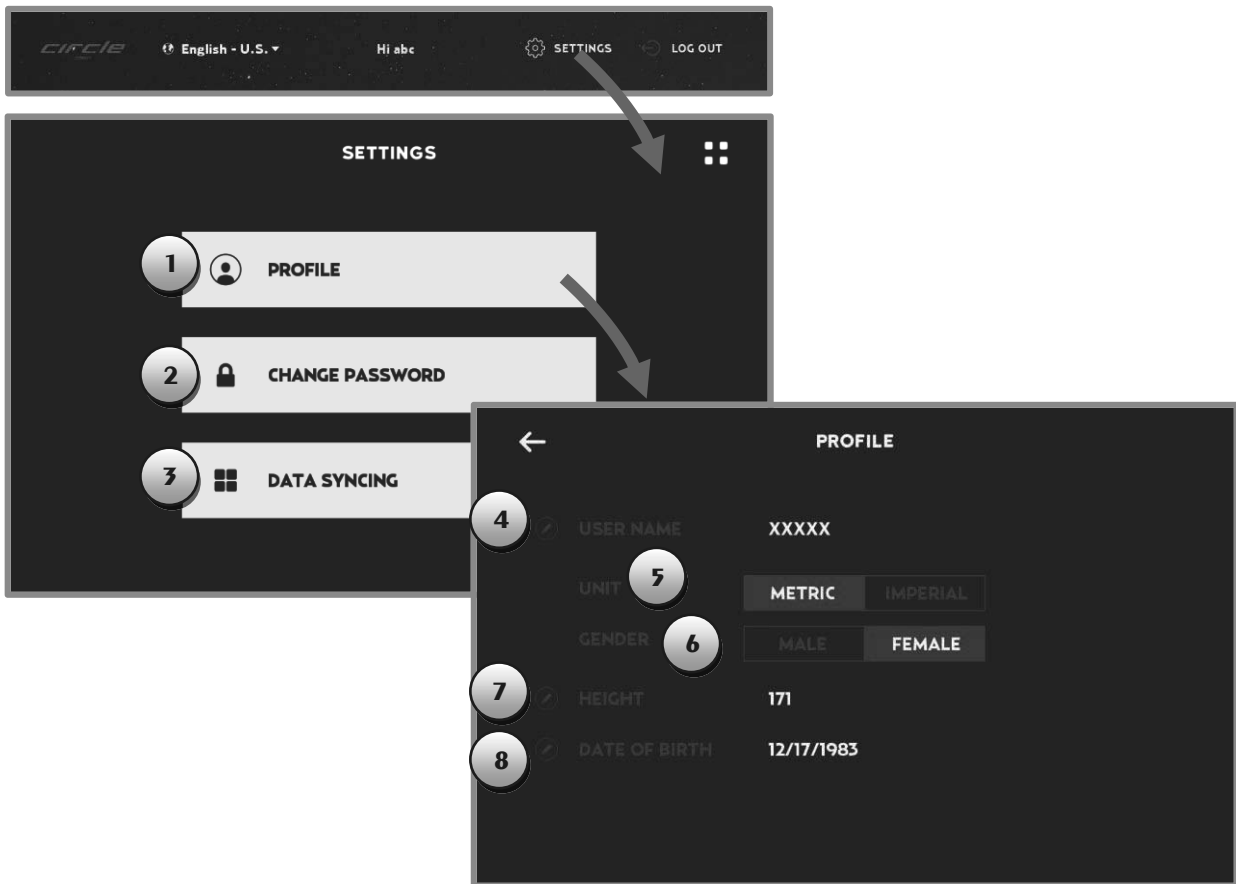

No	Field/ Button	Description
SETTINGS Screen		
1	PROFILE	Tap to skip to PROFILE Screen to edit your personal profile.
2	CHANGE PASSWORD	Tap to skip to CHANGE PASSWORD Screen change your password.
3	DATA SYNCING	Tap to skip to DATA SYNCING Screen to connect/ disconnect with Fitness/ Wearable apps.
PROFLIE Screen		
4	USER NAME	Tap the pencil icon to pop out an on-screen keyboard to edit user name.
5	UNIT	METRIC / IMPERIAL
6	GENDER	MALE / FEMALE
7	HEIGHT	Tap the pencil icon to pop out a screen to set your height.
8	DATE OF BIRTH	Tap the pencil icon to pop out a screen to set your date of birth.

2.4 SETTINGS (Continued)

LOGGED IN > SETTINGS > CHANGE PASSWORD Screen

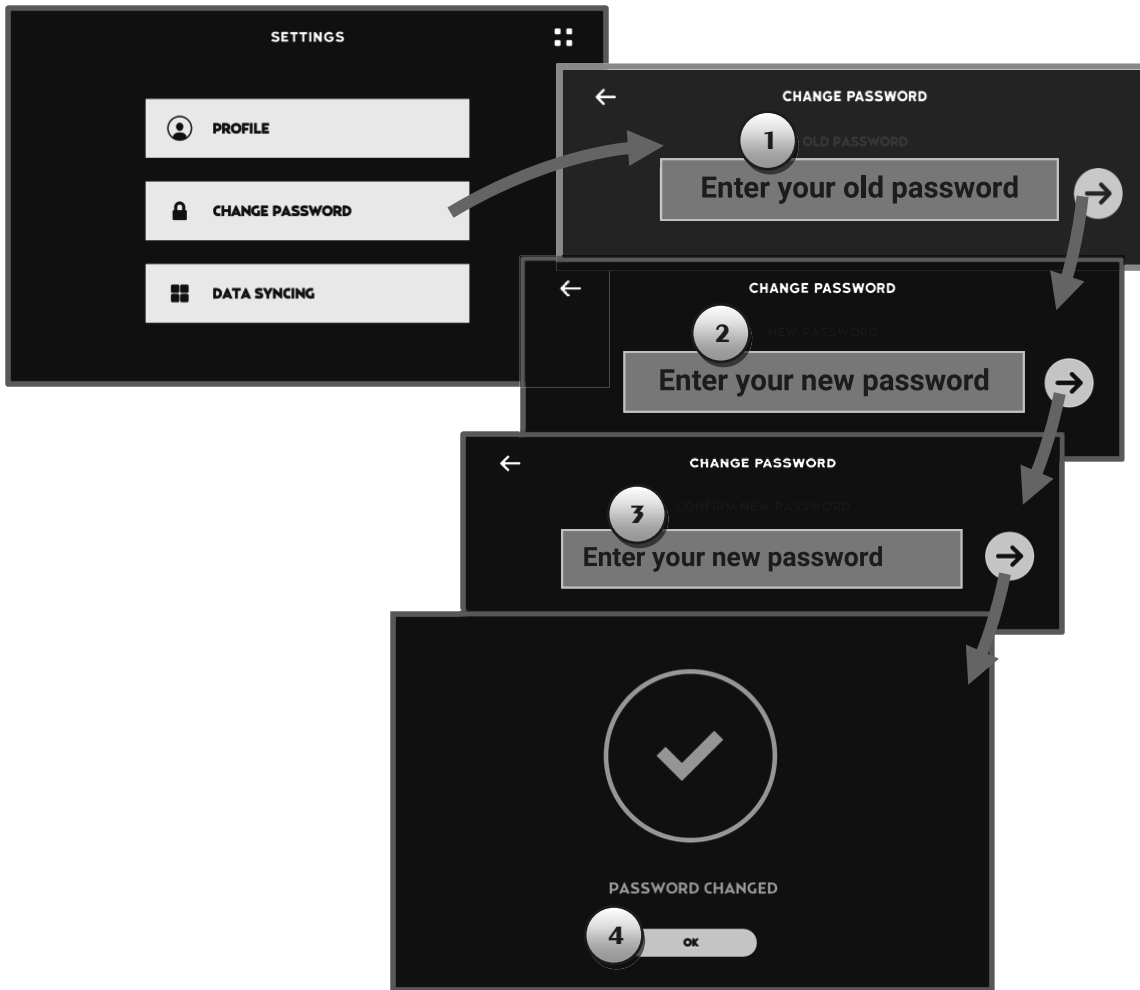

No	Field/ Button	Description
CHANGE PASSWORD Screen:		
Tap to skip to CHANGE PASSWORD Screen change your password.		
1	OLD PASSWORD	Enter your old password.
2	NEW PASSWORD	Enter your new password.
3	CONFIRM NEW PASSWORD	Enter your new password agin.
4	OK	Tap to skip to SETTINGS Screen.
		Tap to HOME Screen.

2.4 SETTINGS (Continued)

Go to HOME Screen > LOGGED IN > SETTINGS > DATA SYNCING Screen



Featured Compatible Apps:

FITNESS APPS

- 1) Google Fit
- 2) MapMyRun
- 3) MapMyWalk
- 4) MapMyRide
- 5) RunKeeper

WEARABLE APPS

- 6) Fibit
- 7) Garmin

NOTE: Available apps may vary by country and operating system.

2.5 FORGOT PASSWORD

Go to HOME Screen > LOG IN Screen > FORGOT PASSWORD Screen

When you forget your password, please tap "**FORGOT PASSWORD?**" on **LOG IN Screen** to get your password.

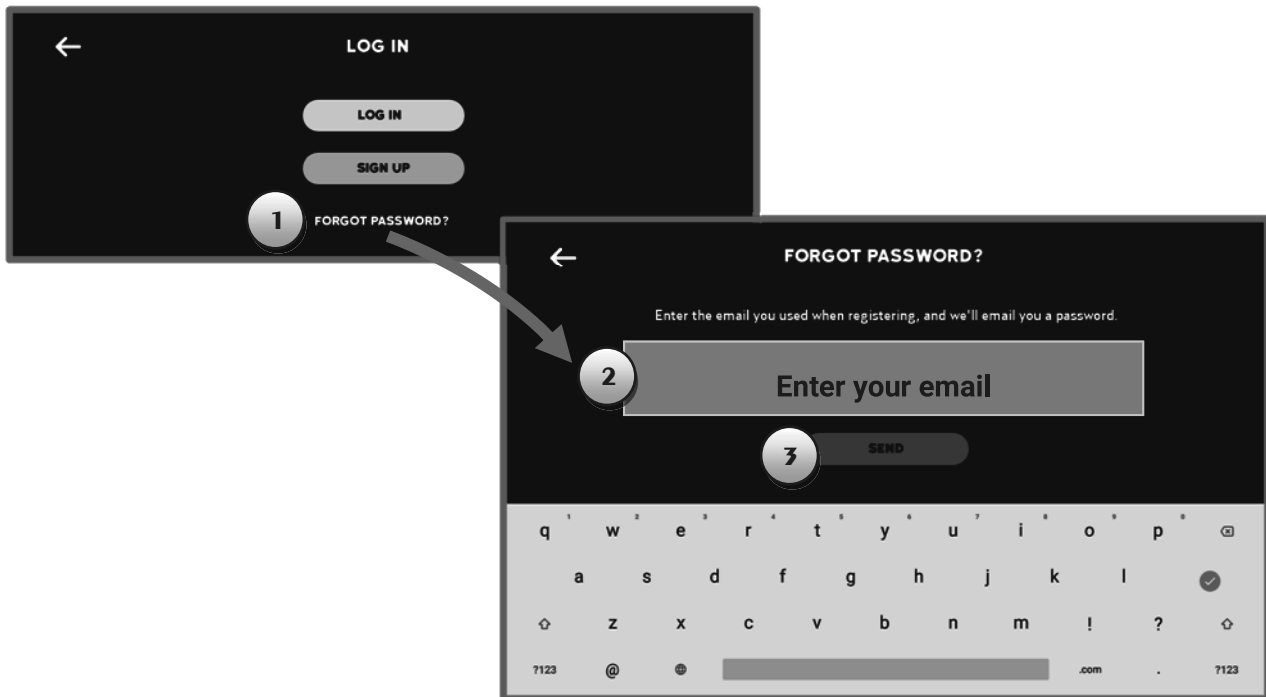

No	Field/ Button	Description
1	FORGOT PASSWORD?	Tap to skip to FORGOT PASSWORD Screen.
2	ENTER YOUR PASSWORD	Tap to pop out an on-screen keyboard to enter the email that you used when registering.
3	SEND	Tap to send an email to your mailbox.

2.6 CIRCLECLOUD GO SIGN UP

Go to HOME Screen > LOG IN Screen > CIRCLECLOUD GO SIGN UP Sreen

If you don't have an account, please follow the steps to sign up.

Tap **SIGN UP** on **LOG IN** Screen.



STEP 6: Choose your gender.



STEP 1: Enter your email.

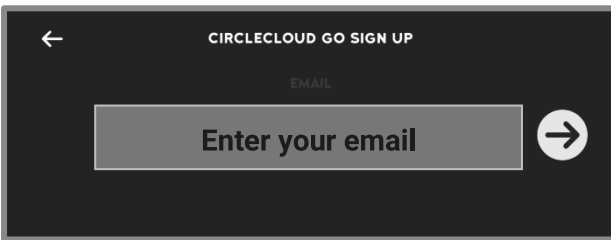

STEP 7: Set your height.

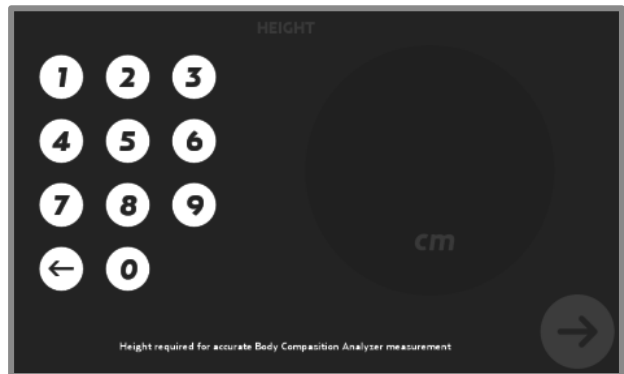

STEP 2: Enter your password.

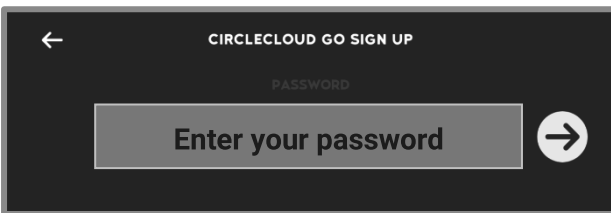

STEP 8: Set your day of birth.



STEP 3: Retyped your password.

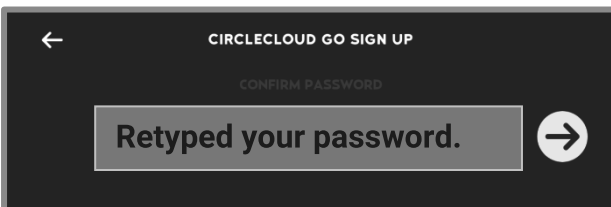

STEP 4: Enter user's name.

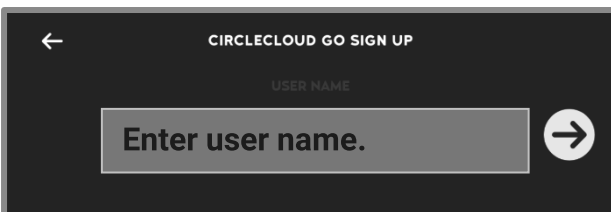

STEP 9: View and agree the privacy policy to complete the register process.

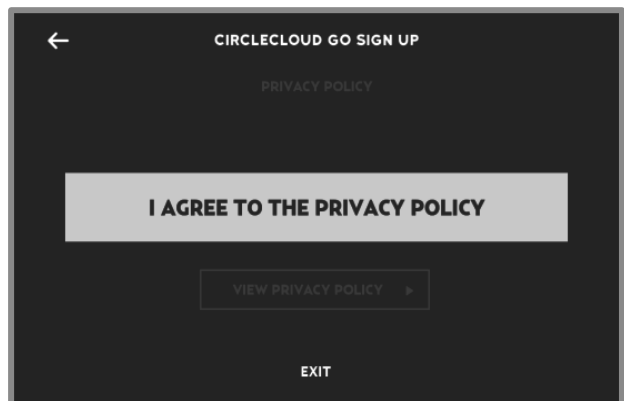

STEP 5: Choose your unit.

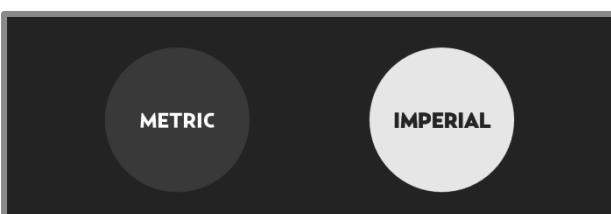

NOTE: Height & Date of Birth are required for accurate Body Composition Analyzer measurement.



2.7 TRAINING

Go to HOME Screen > TRAINING Screen

WARNING: Consult a physician before you start an exercise program. Stop exercising if you feel pain or tightness in your chest, become short of breath, or feel faint. Contact your doctor before you use the equipment again.



We offer comprehensive cardio conditioning courses to help boost aerobic fitness and train your body to endure even more challenging workouts. 9 training programs are provided as below.

No.	Button	Description
1	MANUAL	Work out at a pace and intensity that suits you.
2	ROLLING HILL	Challenge yourself to intervals of various lengths and elevation.
3	MOUNTAIN PEAKS	Bike on a constant incline through this simulated outdoor trail.
4	FATBURN	Work out at a low intensity, letting your deliver plenty of oxygen to your muscle burn more fat reserves.
5	INCLINE	Bike at a steady but intense incline on this simulated outdoor trail.
6	STRENGTH	Challenge yourself with this high intensity workout.
7	INTERVAL	Want to increase your stamina? This interval training program will get you there!
8	CONSTANT WATT	What is your target watt output? This program adjusts intensity level according your pedaling speed, to help you reach your goal.
9	SET A GOAL	Select a specific target to reach and go for it.
		Tap to skip to HOME Screen.
		Tap to view corresponding descriptions.

2.7 TRAINING (Continued)

Go to HOME Screen > TRAINING Screen > MANUAL (Setting Screens)



STEP 1: WEIGHT Setting

Setting range:

35.0 ~ 220.0(kg) / 77 ~ 485.0 (lb)

Tap white arrow button to back to TRAINING screen if you want to change a workout program.

Tap arrow button to next page.



STEP 2: TIME Setting

Setting range: 10~120 min

Tap white arrow button to back previous page if you need to correct your settings.

Tap yellow arrow button to next page.

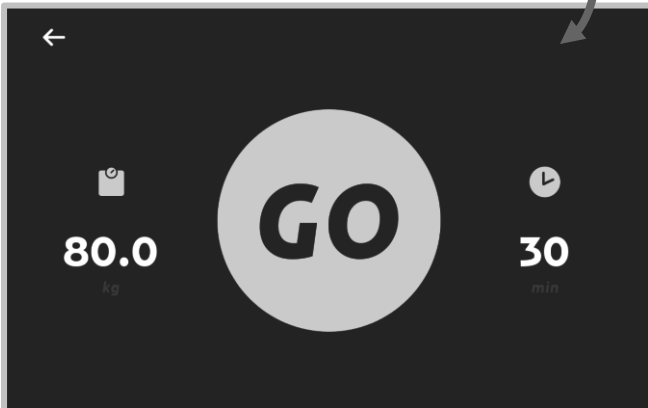

STEP 3: CONFIRM Your Settings

Confirm your settings on this page.

Tap white arrow button to back previous page if you need to correct your settings.

Tap GO to begin your work (skip to Workout Screen).

2.7 TRAINING (Continued)

TRAINING Screen > ROLLING HILL/ MOUNTAINT PEAK/ FATBURN/ INCLINE /STRENGTH/ INTERVAL (Setting Screens)

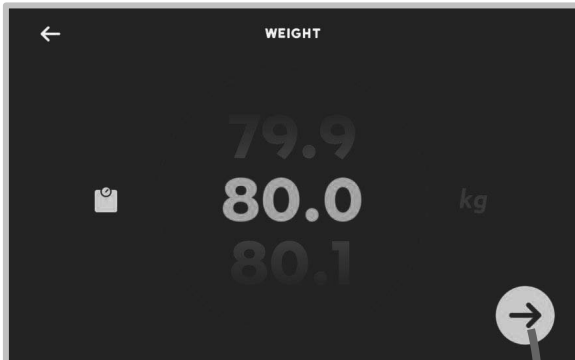

STEP 1: WEIGHT Setting

Setting range: 35.0 ~ 220.0(kg) or 77 ~ 485.0 (lb)

Tap yellow arrow button to next page.



STEP 2: TIME Setting

Setting range: 10~120 min

Tap white arrow button to back previous page.

Tap yellow arrow button to next page.

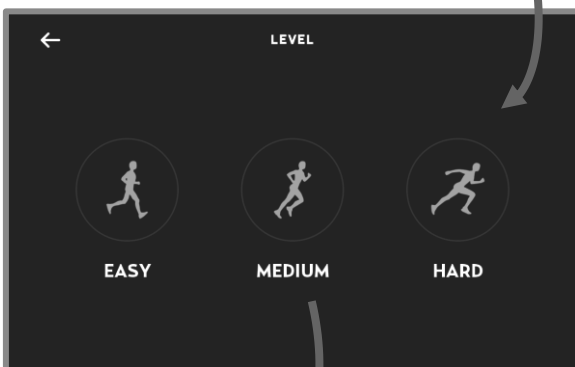

STEP 3: LEVEL Setting

Tap one of the levels (**EASY/ MEDIUM/ HARD**) to set your workout intensity and skip to next page.

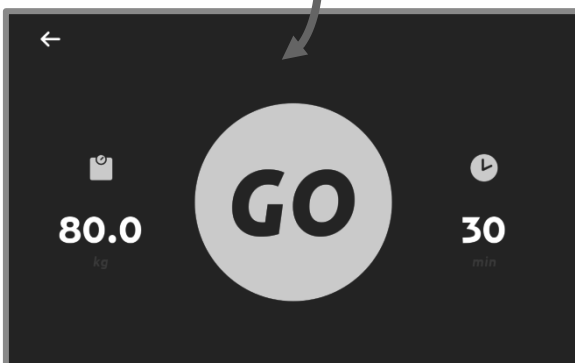

STEP 4: CONFIRM Your Settings

Confirm your settings on this screen.

Tap white arrow button to back previous page if you need to correct your settings.

Tap GO button to begin your workout. **(Skip to Workout Screens)**

2.7 TRAINING (Continued)

TRAINING Screen > CONSTANT WATT (Setting Screens)

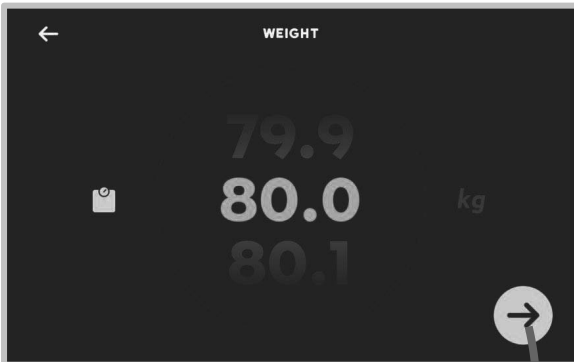

STEP 1: WEIGHT Setting

Setting range: 35.0 ~ 220.0(kg) or 77 ~ 485.0 (lb)

Tap white arrow button to back previous page.

Tap yellow arrow button to next page.



STEP 2: TIME Setting

Setting range: 10~120 min

Tap white arrow button to back previous page.

Tap yellow arrow button to next page.



STEP 3: WATT Setting

Setting range: 50~400W

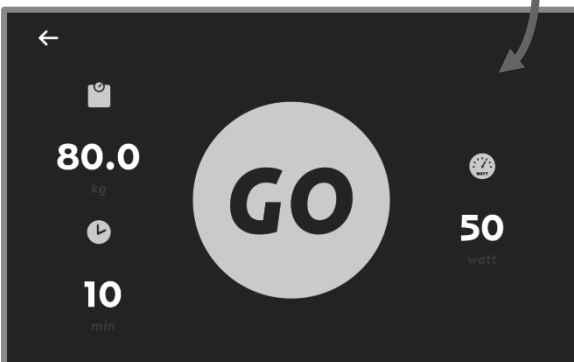

STEP 4: CONFIRM Your Settings

Confirm your settings on this screen.

Tap white arrow button to back previous page if you need to correct your settings.

Tap GO button to begin your workout.
(Skip to Workout Screens)

2.7 TRAINING (Continued)

Go to HOME Screen > TRAINING Screen > SET A GOAL (Setting Screens)



STEP 1: WEIGHT Setting

Setting range: 35.0 ~ 220.0(kg) / 77 ~ 485.0 (lb)

Tap white arrow button to back previous page.

Tap yellow arrow button to next page.

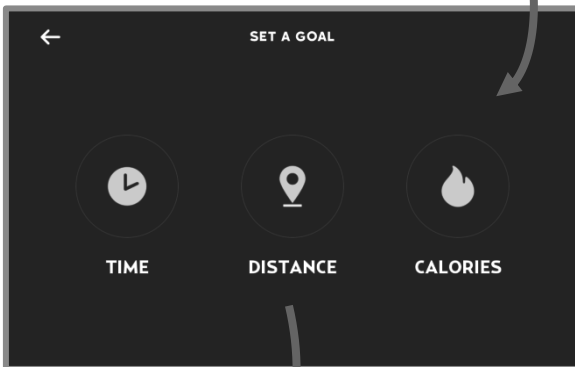

STEP 2: GOAL Selection

Select a specific target (Time/ Distance/ Calories) and skip to next page.

STEP 3: GOAL Setting (Time/ Distance/ Calories)



Range: 10-120 min

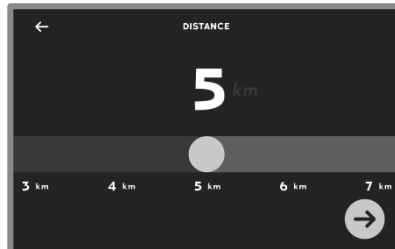

Range: 1-50 km /1-30 mile

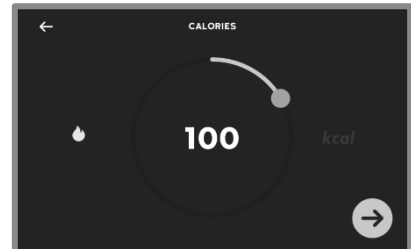

Range: 1000-2000 kcal

Tap yellow arrow button to next page.

STEP 4: CONFIRM Your Settings

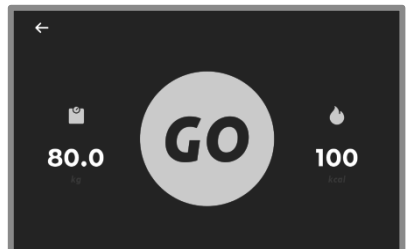
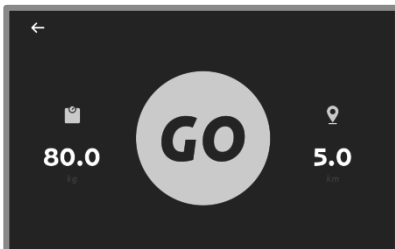
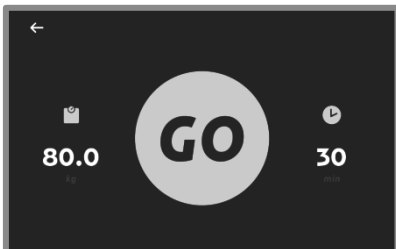

Tap white arrow button to back previous page if you need to correct your settings.

Tap GO to begin your workout. (Skip to Workout Screens)

2.7 TRAINING (Continued)

TRAINING Screen > SETTING Screens > WORKOUT Screens

Tap **PROFILE**/ **SIMPLE**/ **LAP** to switch the workout display mode.

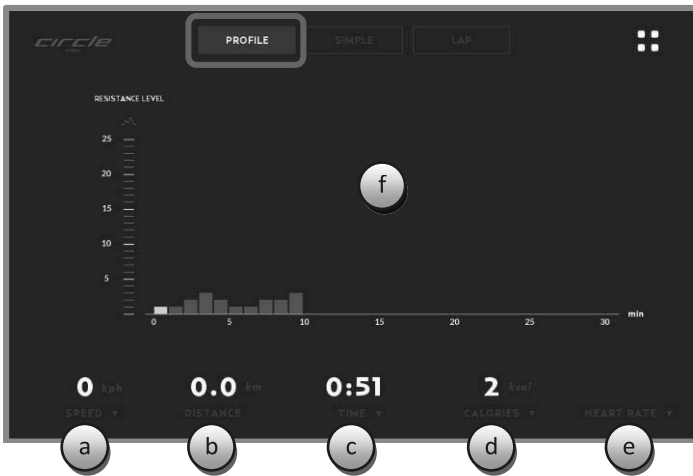

PROFILE: Display the workout information and graphic. Display items are listed as below.

- a) SPEED/ AVG. SPEED/ RPM/ WATT
- b) DISTANCE
- c) TIME/ TIME REMAINING
- d) CALORIES/ CAL/ METS
- e) HEART RATE, AVE. HEART RATE
- f) Workout graphic



SIMPLE: Display the simple workout information by 1 main information window and 3 sub information windows. Display items are listed as below.

- a) DISTANCE/ SPEED / AVERAGE SPEED/ WATT
- b) CALORIES, CAL/HR, METS
- c) HEART RATE, AVE. HEART RATE
- d) TIME, TIME REMAINING

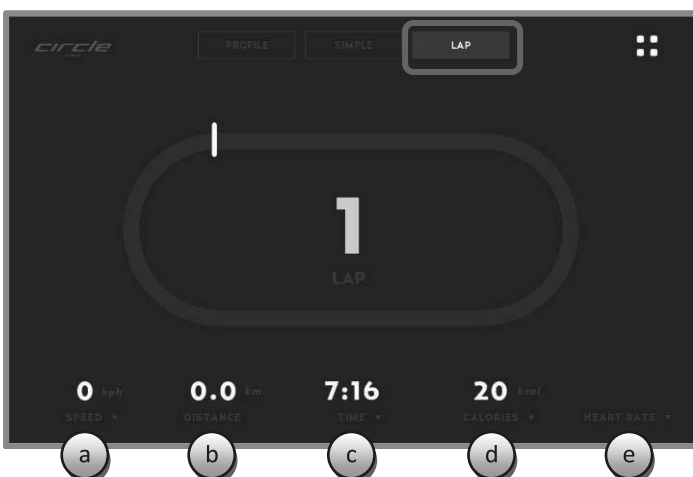

LAP: Display the workout information via lap. Display items are listed as below.

- a) SPEED/ AVG. SPEED/ RPM/ WATT
- b) DISTANCE
- c) TIME/ TIME REMAINING
- d) CALORIES, CAL/HR, METS
- e) HEART RATE, AVE. HEART RATE

▼ Tap to switch display items.

☰ Tap to skip HOME Screen.

2.7 TRAINING (Continued)

TRAINING Screen > SETTING Screens > SUMMARY Screens



Readouts of Training Programs

No.	Field/ Button	Description
1		Displays the title of training program.
2	DURATION (TIME)	Displays the total accumulated time during your workout.
3	DISTANCE	Displays the total accumulated distance mile (or kilometer) during your workout.
4	CALORIES	Displays the total accumulated calories burned during your workout.
5	AVG. SPEED	Displays the average speed.
6	AVG. WATT	Displays the average pedaling RPM.
7	AVG. HEART RATE	Displays the average heart rate during your workout.
8	MAX. HEART RATE	Displays the max. heart rate during your workout.
9		Displays the profile of your workout.
10	DONE	Tap to HOME Screen whether if you had logged in or not.



NOTE: Your workout information displays in Summary Page and will be uploaded to CircleCloud if you had logged in.

2.8 HEART RATE CONTROL

Go to HOME Screen > HEART RATE CONTROL Screen

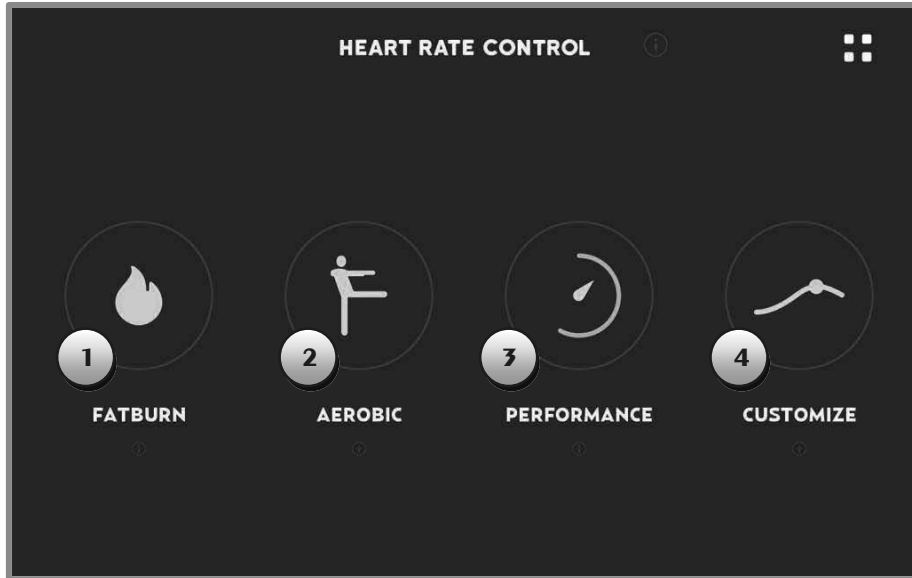
Heart Rate Control maintains the heartbeats per minutes you select by controlling the exercise speed and intensity of your cardio equipment to optimize your workout.



No.	Field/ Button	Description
1	FATBURN	Sets your maximum heart rate to 65% . This program will adjust the intensity accordingly in order to help you reach your target heart rate. - Setting range: (220-Age) x 60% to (220-Age) x 70% - Default setting: (220-Age) x 65% - Tap to skip to setting screens (refer to next page).
2	AEROBIC	Sets your maximum heart rate to 75% . This program will adjust the intensity accordingly in order to help you reach your target heart rate. - Setting range: (220-Age) x 71% to (220-Age) x 80% - Default setting: (220-Age) x 75% - Tap to skip to setting screens (refer to next page).
3	PERFORMANCE	Sets your maximum heart rate to 85% . This program will adjust the intensity accordingly in order to help you reach your target heart rate. - Setting range: (220-Age) x 81% to (220-Age) x 90% - Default setting: (220-Age) x 85% - Tap to skip to setting screens (refer to next page).
4	CUSTOMIZE	Sets a target heart rate. This program will adjust the intensity level accordingly to help you to reach your goal. Tap to skip to setting screens (refer to next page). - Default setting: 120 BPM
		Tap to skip to HOME Screen.
		Tap to view corresponding descriptions.

2.8 HEART RATE CONTROL (Continued)

Go to HOME Screen > HEART RATE CONTROL Screen > SETTING Screens



STEP 1: WEIGHT Setting

Setting range: 35.0 ~ 220.0(kg) or
77 ~ 485.0 (lb)

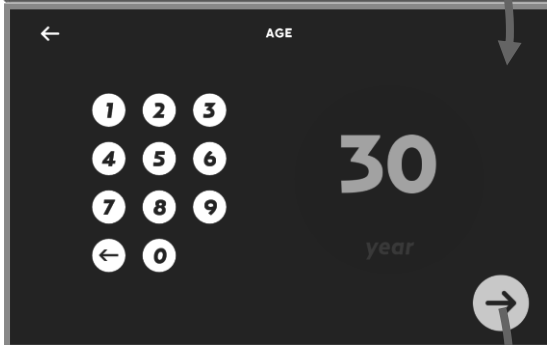

STEP 2: AGE Setting

Setting range: 10~99 year



STEP 3: TIME Setting

Set your time of heart rate control program.

Setting range: 10- 120(min)

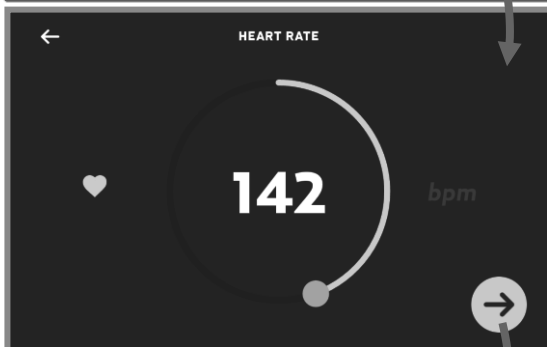

STEP 4: HEART RATE

System will calculate your heart rate beat automatically based on your age, you can adjust your heart rate beat if needed.



STEP 5: CONFIRM Your Settings

Confirm your settings on this screen.

Tap white arrow button to back previous page if you need to correct your settings.

Tap **START** to begin your workout.
(Skip to **WORKOUT** Screen)

2.8 HEART RATE CONTROL (Continued)

HEART RATE CONTROL Screen > SETTING Screens > WORKOUT Screens



PROFILE - Display Items

- a) CALORIES, CAL/HR, WATT, METS
- b) DISTANCE, SPEED, AVG. SPEED, RPM
- c) TIME, TIME REMAINING
- d) HEART RATE
- e) TARGET H.R.
- f) Your workout profile

 Tap to skip HOME Screen.



SIMPLE - Display Items

- a) DISTANCE, PACE, AVERAGE PACE
- b) CALORIES, CAL/HR., METS
- c) TIME, TIME REMAINING
- d) HEART RATE
- e) TARGET H.R.

 Tap to skip HOME Screen.

NOTE: If no heart rate is detected, a message “No heart reate detected. Please put on your chest belt ro place your hands on the heart rate sensor.” will pop out.

Tap **STOP** (membrane button) or reached your target heart rate to skip to SUMMARY Screen. (Refer to next page.)

2.8 HEART RATE CONTROL (Continued)

HEART RATE CONTROL Screen > SETTING Screens > WORKOUT Screens > SUMMARY Screen

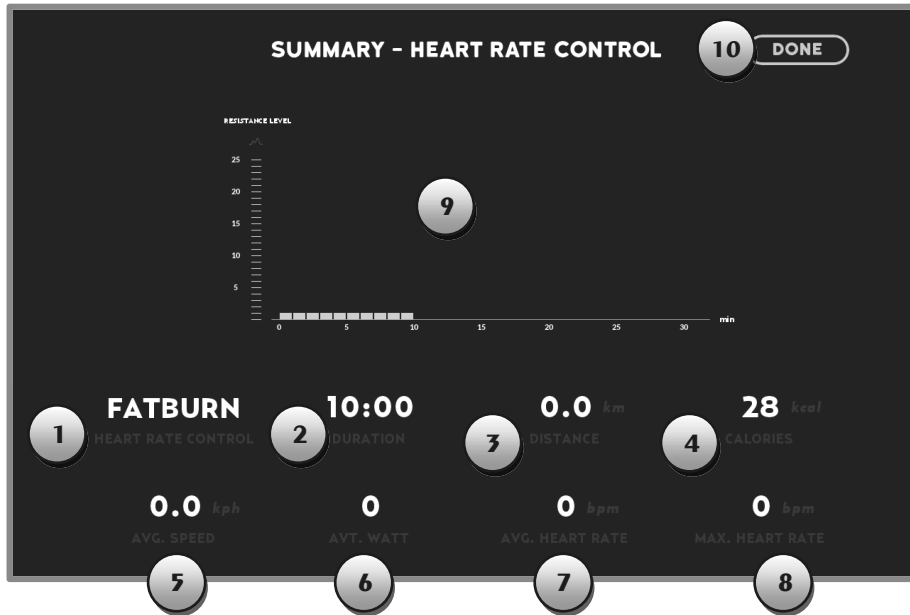

Readouts of Heart Control Programs

No.	Field/ Button	Description
1		Displays the title of heart control program.
2	DURATION (TIME)	Displays the total accumulated time during your workout.
3	DISTANCE	Displays the total accumulated distance mile (or kilometer) during your workout.
4	CALORIES	Displays the total accumulated calories burned during your workout.
5	AVG. SPEED	Displays the average speed.
6	AVG. WATT	Displays the average pedaling RPM.
7	AVG. HEART RATE	Displays the average heart rate during your workout.
8	MAX. HEART RATE	Displays the max. heart rate during your workout.
9		Displays the profile of your workout.
10	DONE	Tap to HOME Screen whether if you had logged in or not.

NOTE: Your workout information displays in SUMMARY Screen and will be uploaded to CircleCloud if you had logged in.

2.9 TARGET TRAIN

Go to HOME Screen > TARGET TRAIN Screen

TARGET TRAIN is a cloud based program enables you to set fitness goals and track progress up to the minute with its real-time connection with CircleFit wellness app.

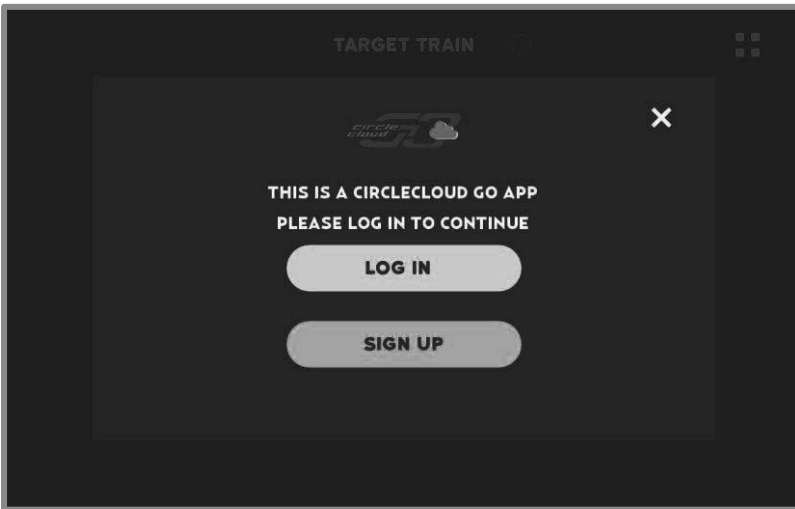

Tap **LOG IN** to Login Screen.
(Refer to chapter 3.3 LOGIN.)

Tap **SIGN UP** to register an account. (Refer to chapter 2.6 CIRCLE CLOUD GO SIGN UP.)

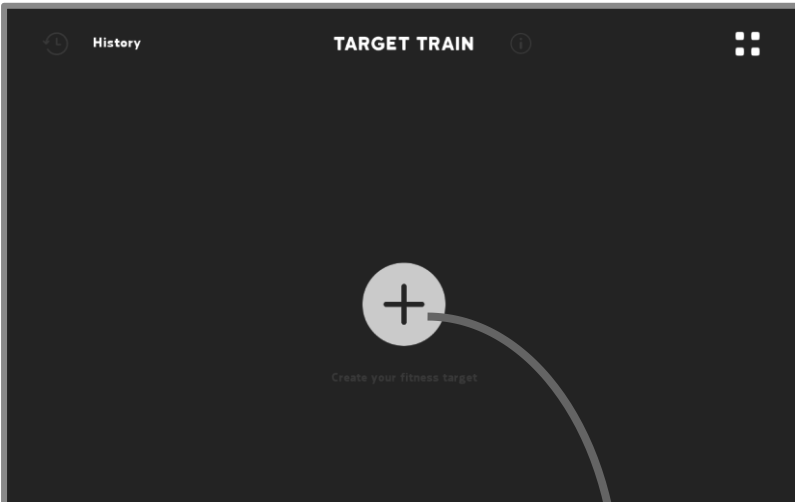

Tap **+** to create your fitness target.

NOTE: 3 fitness targets can be chosen as your target.



TARGET TRAIN comes with 5 difference exercise targets, keeping you motivated and on track for your fitness plan.

Choose the one of the following as your workout target.

- 1) DISTANCE
- 2) CALROIES
- 3) EXERCISE FREQUENCY
- 4) WEIGHT
- 5) BODY FAT%

2.9 TARGET TRAIN (Continued)

TARGET CHOOSE Screen > DISTANCE Setting Screens

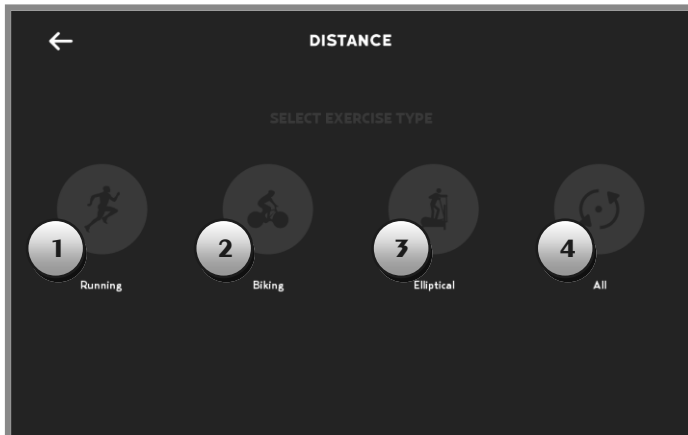

STEP 1: SELECT EXERCISE TYPE

Choose the one of the following as your exercise type.

- 1) Running
- 2) Biking
- 3) Elliptical
- 4) All

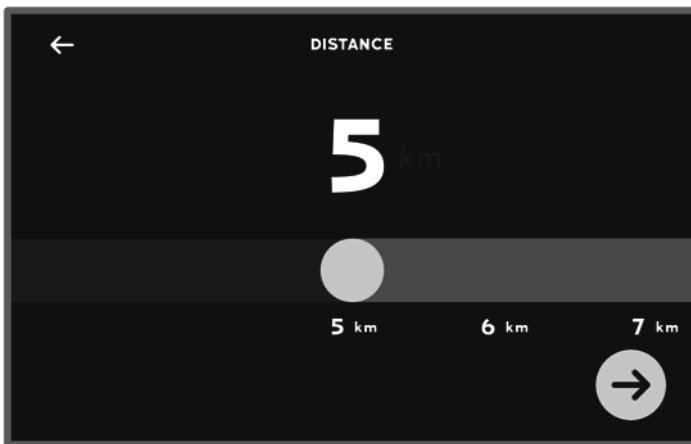

STEP 2: DISTANCE SETTING

Set your workout distance.

Setting range:
5 ~ 999 km (3.1 ~ 62.4 mi)
Preset: 5km (3.1mi)

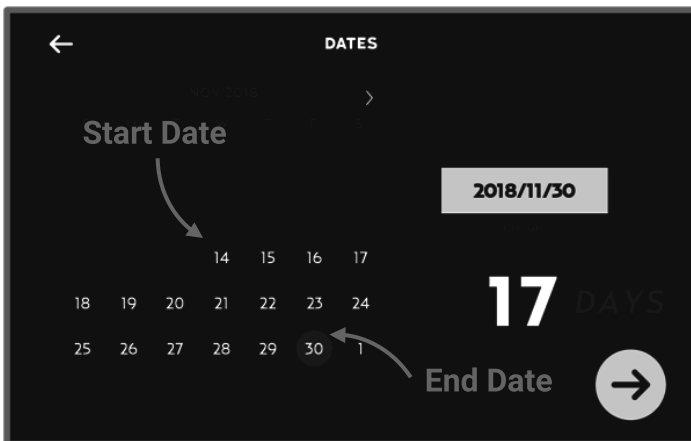

STEP 3: PERIOD SETTING

Start Date: Current date.

End Date: Choose end date for your target and total days will displayed on right of screen.

Tap yellow arrow to next screen.

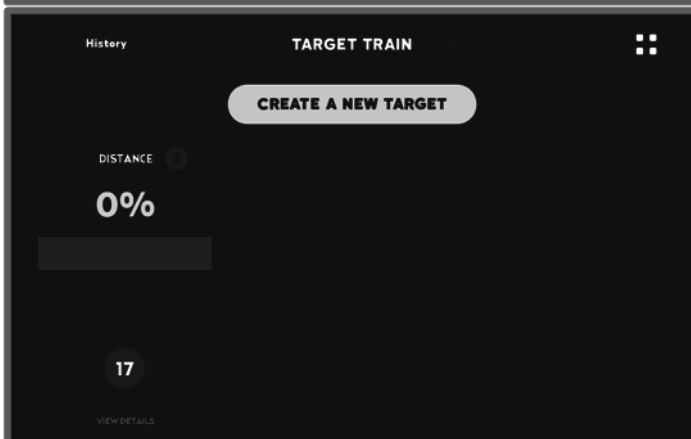

STEP 4: COMPLETE YOUR SETTING

2.9 TARGET TRAIN (Continued)

TARGET CHOOSE Screen > CALORIES Setting Screens

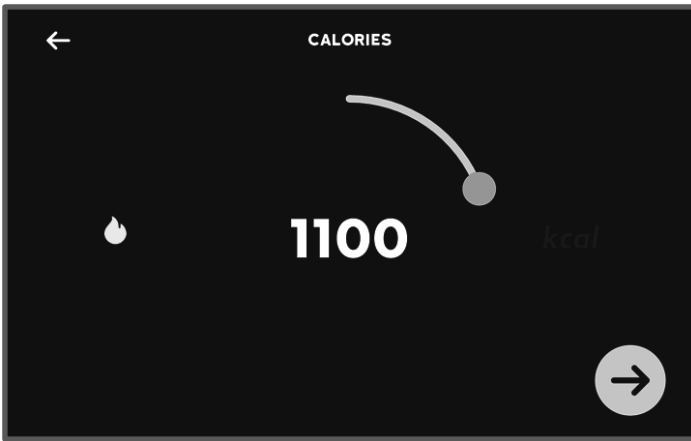

STEP 1: SET YOUR TARGET CALORIES

Setting range: 100 ~ 99900 cal

Preset: 100 cal

Tap yellow arrow to next screen.

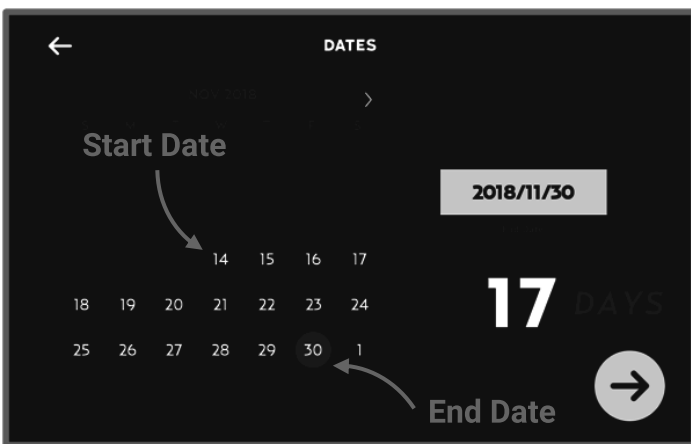

STEP 2: PERIOD SETTING

Start Date: Current date.

End Date: Choose end date for your target and total days will displayed on right of screen.

Tap yellow arrow to next screen.

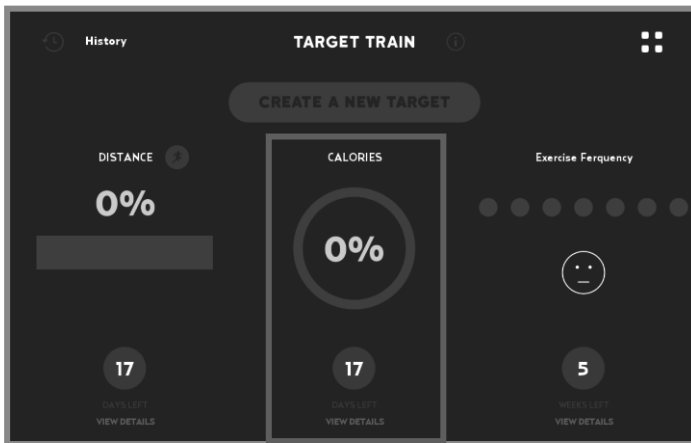

STEP 3: COMPLETE YOUR SETTING

 Tap to skip to HOME Screen.

2.9 TARGET TRAIN (Continued)

TARGET CHOOSE Screen > EXERCISE FREQUENCY Setting Screens

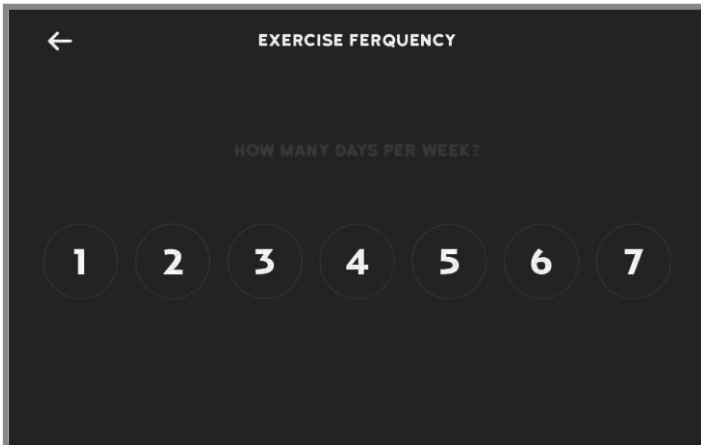

STEP 1: SET YOUR EXERCISE FREQUENCY

Tap one of the numeric buttons to select the target workout days per week.

Setting range: 1~7

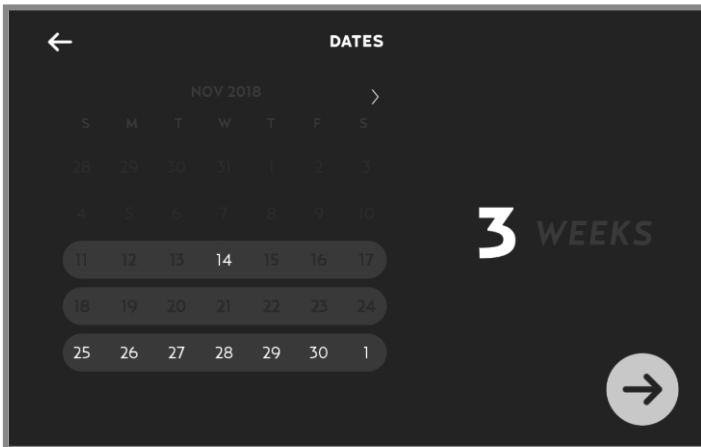

STEP 2: PERIOD SETTING

Start Week: Current week.

End Week: Choose end week for your target and total weeks will displayed on right of screen.

Tap yellow arrow to next screen.

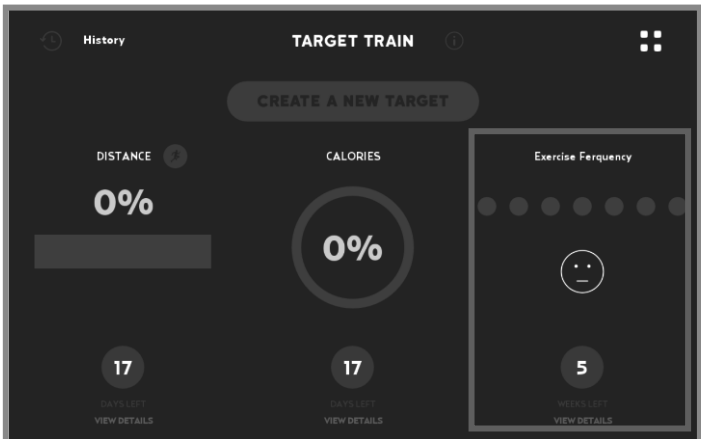

STEP 3: COMPLETE YOUR SETTING

 Tap to skip to HOME Screen.

2.9 TARGET TRAIN (Continued)

TARGET CHOOSE Screen > WEIGHT Setting Screens



STEP 1: SET YOUR CURRENT WEIGHT

Setting range: 35-220 kg (70-500 lb)



STEP 2: SET YOUR TARGET WEIGHT

Setting range: 35-220 kg (77-484 lb)

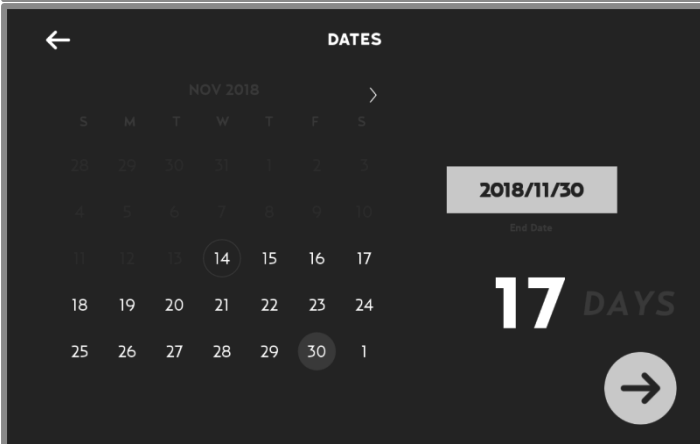

STEP 3: PERIOD SETTING

Start Date: Current date.

End Date: Choose end date for your target and total days will displayed on right of screen.

Tap yellow arrow to next screen.



STEP 4: COMPLETE YOUR SETTING

2.9 TARGET TRAIN (Continued)

TARGET TRAIN Screen > TARGET CHOOSE Screen > BODY FAT% Screens



STEP 1: SET YOUR CURRENT BODY FAT%

Setting range: 1-50%



STEP 2: SET YOUR TARGET BODY FAT%

Setting range: 2-50%

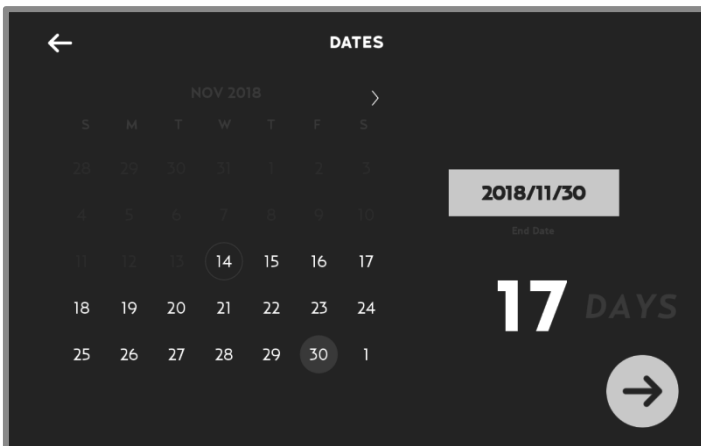

STEP 3: PERIOD SETTING

Start Date: Current date.

End Date: Choose end date for your target and total weeks will displayed on right of screen.

Tap yellow arrow to next screen.

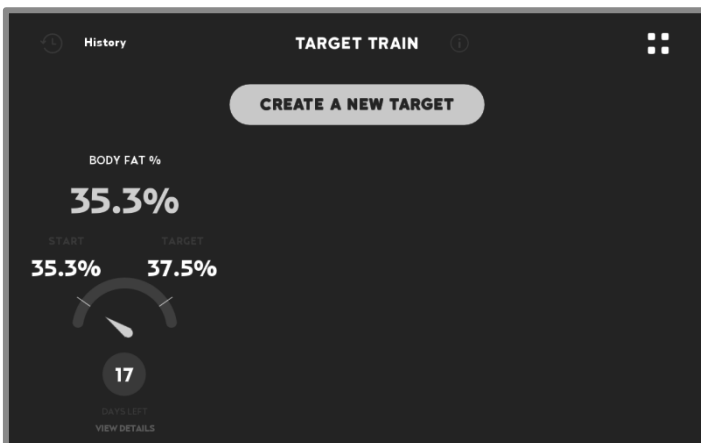

STEP 4: COMPLETE YOUR SETTING

2.9 TARGET TRAIN (Continued)

TARGET TRAIN Screen > History Screen

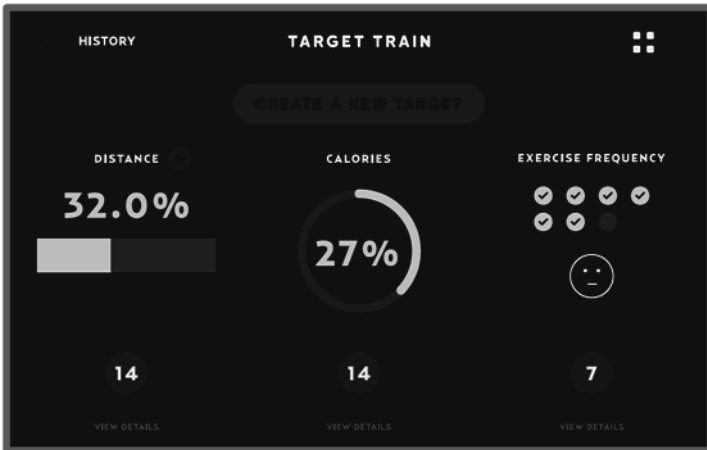

HISTORY (HISTORY)

Tap to view the history of your target.



HISTORY SCREEN

Tap **EDIT** to edit your history of target train.



Gold Star: target is achieved.



Thumbs-up: target is interrupted before you achieved.



Silver Star: achieved the target after times up and continued the target.

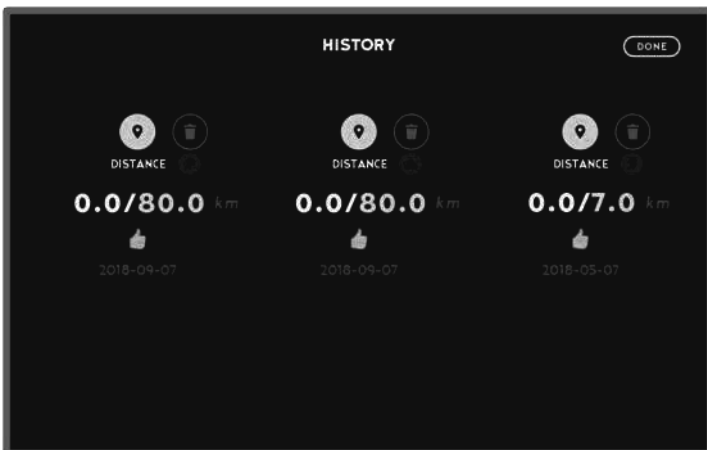

EDIT HISTORY SCREEN



Tap to delete your record.



Tap to skip to history screen.

2.10 MY PERFORMANCE

Go to HOME Screen > MY PERFORMANCE Screen

See your workout performance from cardio equipment, exercise apps and fitness wearables. Compare the results and challenge yourself further!

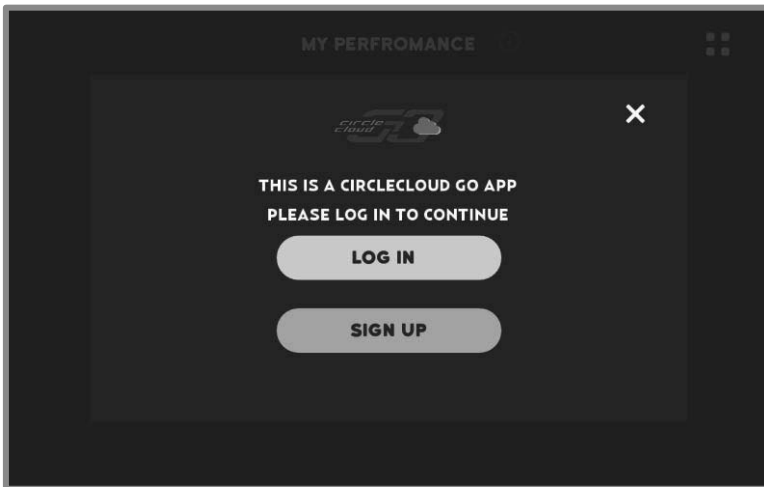

Tap **LOG IN** to LOGIN Screen. (Refer to chapter 2.3 LOGIN.)

Tap **SIGN UP** to register an account. (Refer to chapter 2.6 CIRCLE CLOUD GO SIGN UP.)



You can get your personal work information via **SESSION**, **MONTH** and **YEAR**. (Refer to next page)



Tap to skip to HOME Screen.



Tap to view corresponding descriptions.

2.10 MY PERFORMANCE (Continued)

Go to HOME Screen > MY PERFORMANCE Screen

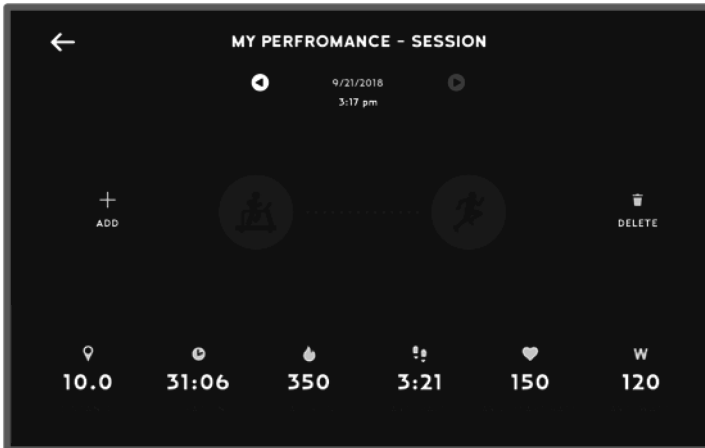

SESSION

Track your cardio equipment usage, outdoor fitness apps and wearable devices to bring you a detailed breakdown of your work history.

Tap **ADD** to add or a session.

Tap **DELETE** to delete or a session.

Tap arrow button to skip previous screen.



MONTH

Month-to-Month comparison charts break down your monthly performance into convenient charts for you to study and compare.

Tap arrow button to skip previous screen.



YEAR

Year-to-Year charts bring you yearly comparisons of your fitness, allow you to review your long-term workout progress.

Tap arrow button to skip previous screen.



2.11 BODY MANAGER

Go to HOME Screen > BODY MANAGER Screens

Body Manager is designed to measure and track your body fitness via Circle Fitness IBA/ InBody 570 and CircleFit wellness app.

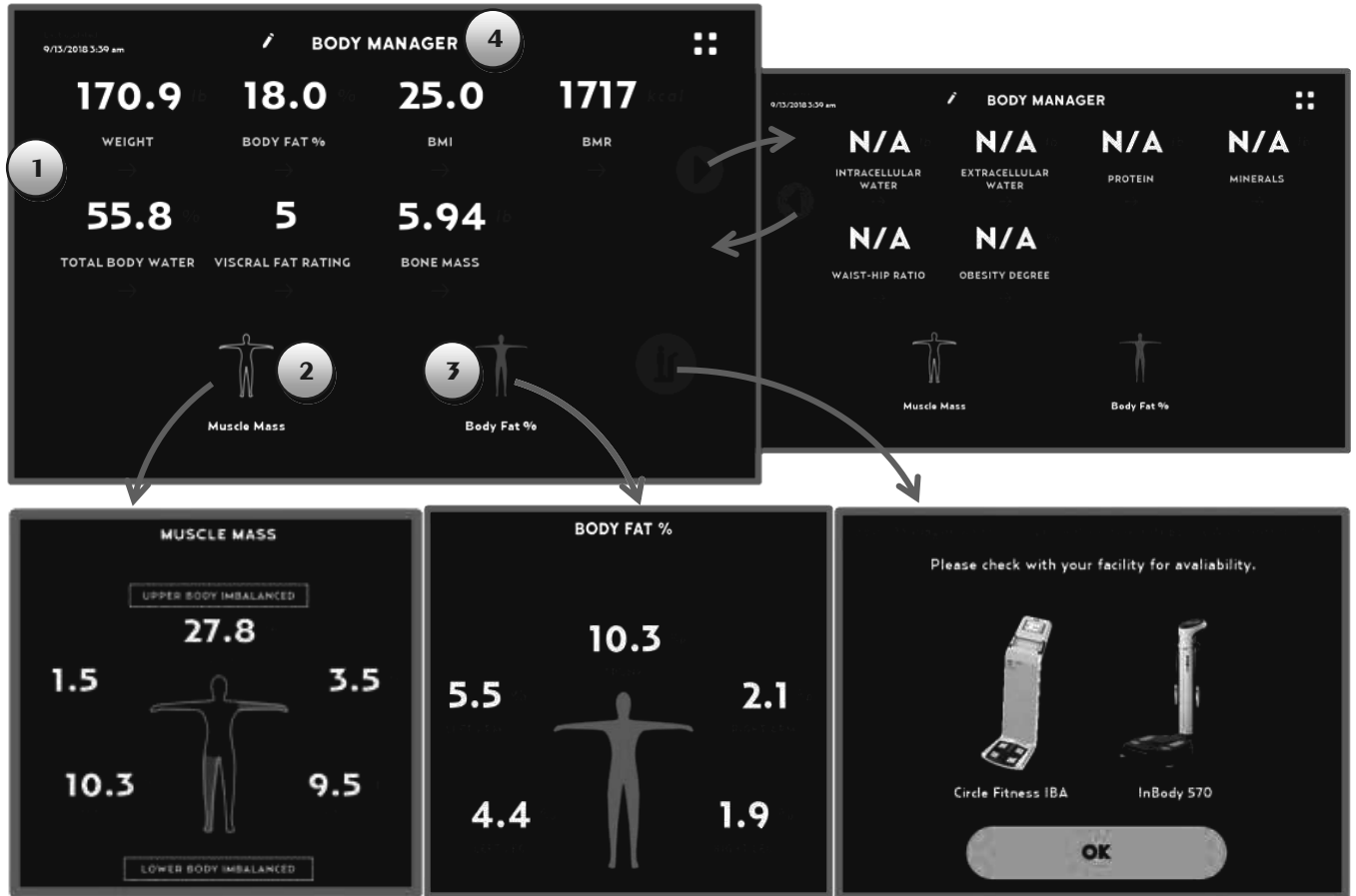
NOTE: Please login before you use this feature.



No.	Field/ Button	Description
1	Key Measurements	Weight/ Body Fat %/ BMI /BMR /Total Body Water/ Visceral Fat Rating/ Bone Mass/ Intracellular Water/ Extracellular Water/ Protein/ Minerals/ Waist-Hip Ration/ Obesity Degree
2	Muscle Mass	Tap to view your distribution of muscle mass.
3	Body Fat %	Tap to view the fat percentage on your body.
4	Pen tool	Tap to edit your measurements.
		Tap to see which equipment works sync with BODY MANAGER.
		Tap to view the history of corresponding measurement.

2.12 MY GYM

Go to HOME Screen > MY GYM Screens

MY GYM keeps you up to date with the latest news (**BULLETIN Screen**), classed and offers from your facility (**CLASS Screen**). It also lets you to customize your personal schedules by adding or removing classes from your calendar (**CLASS Screen & MY CLASS Screen**).

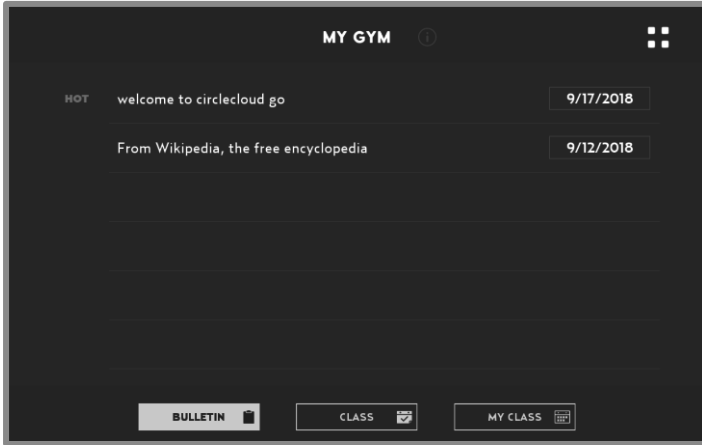

BULLETIN

This feature keeps you updated on the latest news and classes offered by your facilities.

Tap the title on bulletin to get more information.

Tap  to skip HOME Screen.



2.12 MY GYM (Continued)

Go to HOME Screen > MY GYM Screen > CLASS Screen



CLASS

This screen displays the classes offered by your gym in a calendar format.



1) Tap to view the schedule of previous or next week.

2) Class Information

3) ADDED

Tap to add this class to your calendar.

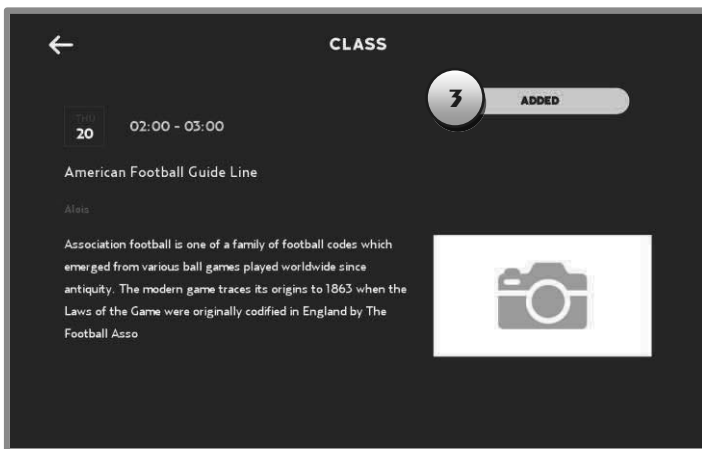

2.12 MY GYM (Continued)

Go to HOME Screen > MY GYM Screen > MY CLASS Screen

NOTE: This feature needs to be logged in.



MY CLASS

This page allows you to edit your classes.



1) Tap to view the schedule of previous or next week.

2) Class Information



3) REMOVE FROM MY CLASS

Tap to remove this class from your calendar and the screen is shown as below.

2.13 MY WORKOUT

Go to HOME Screen > MY WORKOUT Screens

My Workout allows you to set resistance level for each interval to create your own workout program.

NOTE: Please login before using MY WORKOUT. Refer to “**Chapter 2.6 Circlecloud Go Sign Up**” if you don't have an account.



Tap **CREATE YOUR WORKOUT** to start customizing.

NOTE: Up to 3 workout programs can be created.

ENTER YOUR WORKOUT NAME

Tap the blank area to pop out an on-screen keyboard to enter your workout name.

SET YOUR INTERVAL

Set your interval of Time and resistance level.

NOTE: 50 interval sets can be set.

Tap to next screen.

2.13 MY WORKOUT(Continued)

Go to HOME Screen > MY WORKOUT Screens



Workout Profile Preview Screen

Tap  to back to previous screen.

Tap **Detail** to view your workout settings.

Tap **SAVE** to complete your workout settings and skip to MY WORKOUT PAGE.



Workout Detail Screen

Confirm your settings and tap  to back to previous screen.



Tap **CREATE YOUR WORKOUT** to create another workout.

Tap **START** to begin your workout or tap  to skip HOME Screen.

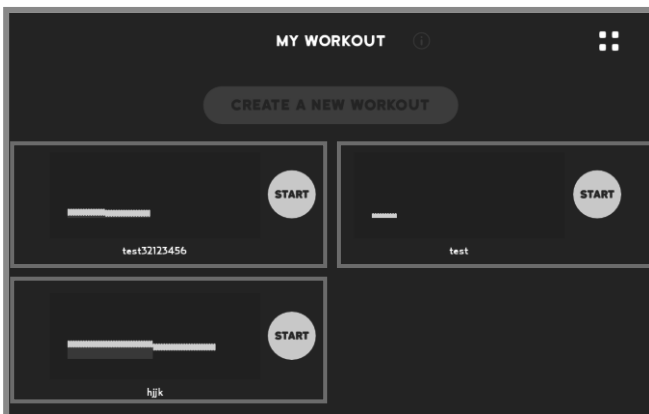

Up to 3 personal My Workouts can be created. (shown as left)